

# Report on examination

Delivered to: University of Tokyo

Product: Xenon recovery tank (TX-2000)

Product ID: #0003, #0004, #0005,

#0006, #0007, #0008

January 2001

Taiyo Material Inc.



1-18-15 Ohmori-nishi Ohta-ku Tokyo 143-0015 Japan

TEL +81-3-3764-0271/FAX +81-3766-6597

## Result of tightness leak test

No.	---	Product No	---				
Product Name	Xenon recovery tank	Dimension	ID520x1546				2 tanks
Design Pressure	8.0 Mpa	Manufacture No.	Approved by	Mr. Otobe	Operated by	Mr. Kobayashi	
		#4058					

## Test

	Product Name	Test Pressure (Mpa)	Duration Temp.	Date	Decision	Examining staff
1	Xenon recovery tank (3-5)	8.5	10min 6°C	20/Jan/2001	OK	Mr. Kobayashi
2	Xenon recovery tank (6-8)	8.3	10min 6°C	20/Jan/2000	OK	Mr. Kobayashi
3						
4						
5						
6						



# X-ray Photography

Otobe Tekkousyo Inc.

No.: 4058-3~8

Product Name: xenon recovery tank

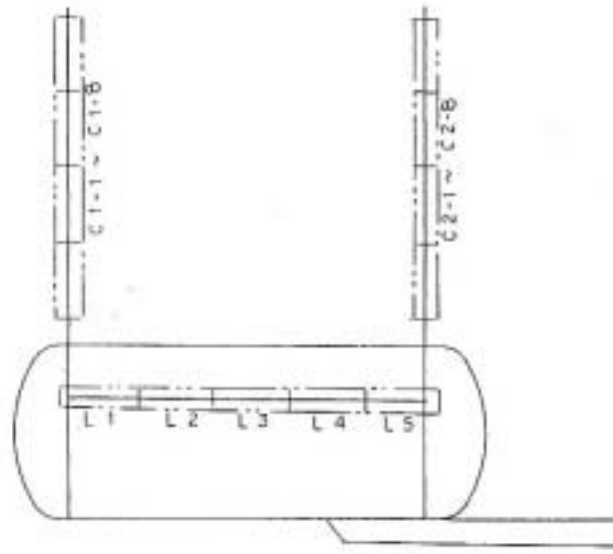

X-ray photography inspection: 100%

Applied law: Japanese regulation for special equipments 51, 52

Inspection method and approval condition: Follow methods described in JIS Z 3106 (regulation for the examination of X-ray photography for stainless welding, and its grade classification)

Approved when the photograph satisfies requirements for the grade 2 or higher in JIS Z 3106.

## Mark, Material, thickness and quantity

Mark	Material	Thickness	Quantity	Mark	Material	Thickness	Quantity
4058-L1~L5	SUS 304	18	5				
4058C1-1~C1-8	SUS 304	18	8				
4058C2-1~C2-8	SUS 304	18	8				

Total 21

## Results of X-ray photography

Unisec Inc.  
4-14-9 chuo Tsurumi-ku Yokohama, 230-0051, Japan  
+81-45-503-3511

12/Jan/2000

Orderer		Otobe Tekkousyo Inc.		Date		4/Dec/2000, 10,11/Jan/2001		Inspector		Mrs. S.Takada, S.Kudo		
Product Name				Applied regulation		Japanese regulation for special equipments 51, 52						
Xenon recovery tank				Decision Criteria		JIS Z3106 above 1-2 2-2						
Equipment for inspection		Producer		Rigaku Denki Inc.		Type		RF300EGS-2				
		Focusing point		2.5x2.5mm		Rated voltage		300kVp		Rated current 5mA		
Film		Name and dimension		Fuji 1x100 85x305mm		Metallic foil screen		Silver foil 0.03mm				
Development condition		Developer		Fujifilm Highrendor		Development temperature		23°C		Development duration 5min		
Outer dimension (mm)		Plate thickness (mm)		Filming Condition								
				Voltage (KVp)		Current(mA)		Distance (mm)		Duration (min.)		Transmission meter
520.0		18.0		205		5		600		1.0		S02
				295		5		700		2.3		S04
Film mark	Grade	Defection		Film mark	Grade	Defection		Film mark	Grade	Defection		
4058-3 L-1	1	BH		C2-3	1	ND		C1-5	1	ND		
-2	1	BH		-4	1	ND		-6	1	ND		
-3	1	ND		-5	1	ND		-7	1	BH		
-4	1	ND		-6	1	ND		-8	1	ND		
-5	1	BH		-7	1	ND		C2-1	1	ND		
C1-1	1	ND		-8	1	ND		-2	1	ND		
-2	1	ND		4058-4 L-1	1	ND		-3	1	ND		
-3	1	ND		-2	1	ND		-4	1	ND		
-4	1	ND		-3	1	ND		-5	1	ND		
-5	1	ND		-4	1	ND		-6	1	ND		
-6	1	ND		-5	1	ND		-7	1	ND		
-7	1	ND		C1-1	1	ND		-8	1	ND		
-8	1	ND		-2	1	ND		4058-5 L-1	1	ND		
C2-1	1	ND		-3	1	BH		-2	1	ND		
-2	1	ND		-4	1	ND		-3	1	ND		
Defection category	1		2					3		4		
Defection mark	BH		SI	P	LF		IP	W		ND		
Defection description	Blow hole		Slag entrained	Pipe	Imperfect fusion		In sufficient merge	Tungsten entrained		.....		

Results of X-ray photography

Film mark	Grade	Defection	Film mark	Grade	Defection	Film mark	Grade	Defection
4058-5 L-4	1	ND	C2-5	1	ND	C1-6	1	ND
-5	1	ND	-6	1	ND	-7	1	ND
C1-1	1	ND	-7	1	ND	-8	1	ND
-2	1	P	-8	1	ND	C2-1	1	ND
ND -3	1	ND	4058-7 L-1	1	BH	-2	1	ND
-4	1	ND	-2	1	ND	-3	1	ND
-5	1	P	-3	1	BH	-4	1	ND
-6	1	ND	-4	1	ND	-5	1	ND
-7	1	ND	-5	1	ND	-6	1	ND
-8	1	ND	C1-1	1	ND	-7	1	ND
C2-1	1	ND	-2	1	ND	=9	1	ND
-2	1	ND	-3	1	ND			
-3	1	BH	-4	1	ND			
-4	1	ND	-5	1	ND			
-5	1	ND	-6	1	ND			
-6	1	ND	-7	1	ND			
-7	1	ND	-8	1	ND			
-8	1	ND	C2-1	1	ND			
4058-6 L-1	1	ND	-2	1	W			
-2	1	ND	-3	1	BH			
-3	1	BH	-4	1	ND			
-4	1	ND	-5	1	ND			
-5	1	ND	-6	1	ND			
C1-1	1	ND	-7	1	ND			
-2	1	ND	-8	1	ND			
-3	1	ND	4058-8 L-1	1	ND			
-4	1	ND	-2	1	ND			
-5	1	ND	-3	1	ND			
-6	1	ND	-4	1	ND			
-7	1	ND	-5	1	ND			
-8	1	ND	C1-1	1	ND			
C2-1	1	ND	-2	1	ND			
-2	1	ND	-3	1	ND			
-3	1	ND	-4	1	ND			
-4	1	ND	-5	1	ND			
Defection category	1	2				3	4	
Defection mark	BH	SI	P	LF	IP	W	ND	
Defection description	Blow hole	Slag entrained	Pipe	Imperfect fusion	In sufficient merge	Tungsten entrained	.....	

# 鏡板検査成績書

注文主: 株式会社 乙部鉄工所 鏡

注文番号: 4058

型式: ED R= 38.0  
r= 168.0

内径 In. Dia.: 520.0

材質: SUS304 板厚: 18.0

材料メーカー: 新日本製鉄株式会社  
Steel Maker: 住友金属工業株式会社

加工方法: 温間プレス

製造番号: 000829-005-0 数量: 12

鏡板略図  
Sketch of head plate

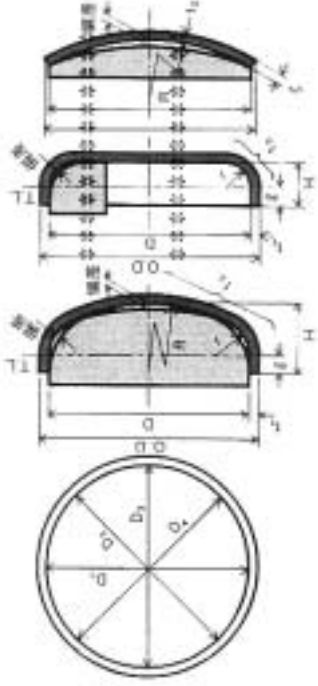

開先詳細図  
Detail of bevel

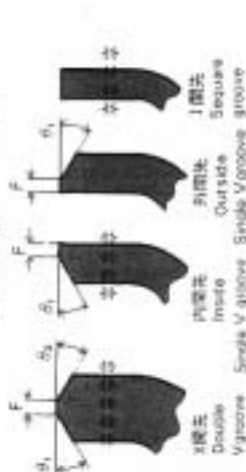

測定項目 Item	円周長 Circumference	内径 Inside Dia.	外径 Outside Dia.	平均値 Average	真円度 Roundness	板厚 Thickness	高さ Height	断面形状 Shape Section	板番 Plate No.	Unit: mm
許容差 Tolerance	1747	520.0	520.0	-1 ~ 3	2.60	(Min. 15.2)	168.0	5		
1	1757	3.0	2.0	3.0	1.00	18.4	17.4	1.0	222818-01	
2	1755	3.0	2.0	3.0	1.00	18.5	17.2	1.0	222818-01	
3	1756	3.0	2.0	2.0	1.00	18.4	17.2	1.0	222818-01	
4	1757	3.0	2.0	2.0	1.00	18.3	17.0	1.0	222818-01	
5	1758	3.0	2.0	3.0	1.00	19.1	18.2	1.0	222818-01	
6	1760	3.0	2.0	3.0	1.00	18.9	18.7	1.0	222818-01	
7	1760	3.0	2.0	3.0	1.00	19.2	18.2	1.0	222818-01	
8	1760	3.0	2.0	3.0	1.00	18.9	18.7	1.0	222818-01	
9	1758	3.0	2.0	3.0	1.00	19.0	18.8	1.0	222818-01	
10	1760	3.0	2.0	3.0	1.00	19.2	18.1	1.0	222818-01	



材料発注番号  
Material Order No.

備考  
Remark

開先及びび、外觀検査合格

上記諸家は規定の検査を行ない、これに合格したことを証明する。  
We hereby certify that this head plate is satisfied with

J I S B 8 2 4 7

Authorized Inspector 高橋 守

# 鏡板検査成績書

注文主: 株式会社 乙部鉄工所 殿

注文番号: 4058

型式: ED R= 38.0  
r= 168.0

内径 In. Dia.: 520.0

材質: SUS304 板厚: 18.0

材料メーカー: 新日本製鉄株式会社

住友金属工業株式会社

加工方法: 温間プレス

製造番号: 000829-005-0 数量: 12

鏡板略図  
Sketch of head plate

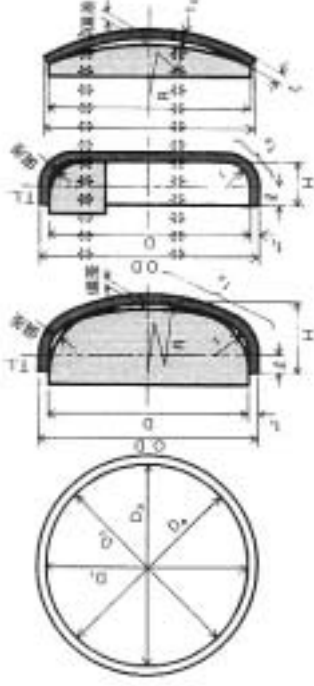

開先詳細図  
Detail of bevel

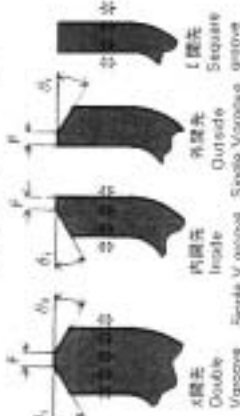

Unit: mm

測定項目 Item	円周長 Circumference	内径 Inside Dia.	外径 Outside Dia.	平均値 Average	真円度 Roundness	板厚 Thickness	高さ Height	形状精度 Shape Deviation	板番 Plate No.	号
許容差 Tolerance	1747	520.0	D1 D2 D3 D4	-1 ~ 3	2.60	18.0 (Min. 15.2)	168.0	5.20		
11	1760	3.0 2.0 2.0 3.0		2.50	1.00	19.1 18.9 18.1	172.0	1.0	222818-01	
12	1756	3.0 2.0 2.0 3.0		2.50	1.00	17.9 17.8 16.7	173.0	1.0	222818-01	
材料発注番号 Material Order No.	備考 Remark 開先及び、外観検査合格									上記諸項は規定の検査を行ない、これに合格したこととを証明する。 We hereby certify that this head plate is satisfied with

日付: 2000/09/20  
Date

日本鏡板工業株式会社  
NIPPON KYOHAN KOGYO CO., LTD.



Authorized Inspector 高橋 守







# 31 INSPECTION CERTIFICATE 検査証明書

72 NO  
010232

Contractor 発注先	Purchaser 発注先	Order No. 発注番号	Remarks 備考
パシハイ	セキソウヒン (090703)		

Chemical Composition 化学成分

Elements 成分	C	Si	Mn	P	S	Cu	Ni	Cr	Mo
Specification 規格	X100 MAX 8	X100 MAX 1.00	X100 MAX 200	X10000 MAX 45	X10000 MAX 30	X10000 MAX 1800	X100 800	X100 1800	
Results 実測	5	30	138	33	25	1840	801		

Mechanical properties 機械的性質

Items 項目	Tension Test 引張試験			Impact Test 衝撃試験		Heat Treatment 熱処理
	Type of Specimen 試験片	Yield strength 引張強さ	Elongation 伸び	Reduction of Area 断面収縮	Type of Specimen 試験片	
Specification 規格	N/MM MIN 205	N/MM MIN 520	% MIN 40	% MIN 60	HB MAX 187	BODY
Results 実測	JIS10	280	642	59	77	1050°C X 5MIN WQ (チアウシンホシ)
Items 項目	Grain Size 結晶粒径	Decarburization 脱炭素	Streak Flow 地味	Body Hardness 製品硬度	Non-Metallic Inclusion 非金属夹杂物	
Results 実測						
Items 項目	Hardenability 焼入れ性					
Results 実測	PT3/8 base					

Hardenability (End Quenching Method) 焼入れ性 (一端焼入れ法)

Results 実測	Heat No. 焼入れ番号	Conditions 条件	Size & Shape 寸法・形状
	1H01D	ST, PM	40 D

Quality Assurance Section Kawasaki Plant

**Daido Steel Co. Ltd.**  
大同特殊鋼株式会社  
川崎工場品質保証室  
〒210 0803 川崎川崎区南河原1-1-1  
TEL: 042-306-3753 (代表)

Date  
発行日: 10-02-13  
Certificate No.  
証明書番号: 1S2147  
Type of Steel  
鋼種: JISG4303-98-SUS304  
Size & Shape  
寸法・形状: 40 D  
Heat No.  
焼入れ番号: 1H01D

Chief of Quality Assurance Section  
*J. Ito*

is hereby certified that the above results are true and correct in every details  
この書類は要求事項を満足していることを証明します。



