

次世代 $\mu^+ \rightarrow e^+ \gamma$ 崩壊探索のための光子ペアスペクトロメータの開発 —ビームテストによるアクティブコンバーターの性能評価—

Developing an experiment for a future search for $\mu^+ \rightarrow e^+ \gamma$
- performance evaluation of the active converter through beam test -

榊原 滯

潘晟^A, Lukas Gerritzen^A, 池田史, 岩本敏幸^A, 松下彩華, 松岡広大^C, 森俊則^A,
西口創^C, 越智敦彦^B, 大谷航^A, 内山雄祐^C, 山本健介, 大矢淳史^A, 横田凜太郎
(東大理, 東大素セ^A, 神戸大理^B, 高工研^C)

2024年9月18日 日本物理学会年次大会

$\mu^+ \rightarrow e^+ \gamma$ search

- Charged lepton flavor violation decay

- $Br(\mu^+ \rightarrow e^+ \gamma) \sim \mathcal{O}(10^{-53})$...SM + ν oscillation
- $Br(\mu^+ \rightarrow e^+ \gamma) \sim \mathcal{O}(10^{-11} \sim 10^{-14})$...predicted in BSM (e.g. SUSY)

- Experiments

- MEG experiment (2009-2013@PSI): $Br(\mu^+ \rightarrow e^+ \gamma) < 4.2 \times 10^{-13}$ (90% C.L.)
- MEG II experiment (2021-) : ongoing with the target sensitivity 6×10^{-14}
- **Future $\mu^+ \rightarrow e^+ \gamma$ experiment** : planning with the target sensitivity of $\mathcal{O}(10^{-15})$

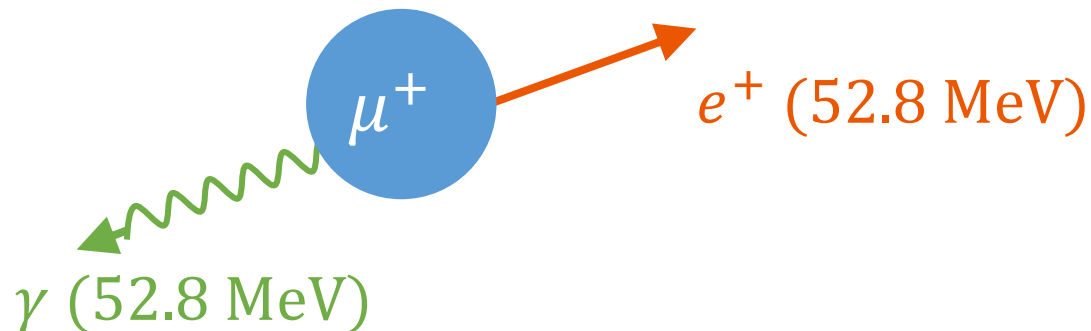

Future experiment of $\mu^+ \rightarrow e^+ \gamma$ search

- **Motivation of search at $O(10^{-15})$ sensitivity**

- Further search for $\mu^+ \rightarrow e^+ \gamma$ (if it was not found in MEG II experiment)
- Measurement of $\mu^+ \rightarrow e^+ \gamma$ after discovery (branching ratio, angular distribution,...) for BSM model selection

- **Muon beam**

the intensity of muon beam at PSI is planned to be increased to $\sim 10^{10} \mu^+ / s$
(High Intensity Muon Beam (HiMB), implemented in 2027-2028)

- **Detector**

- R&D of new detectors with high rate capability & good resolutions is necessary
- main background of $\mu^+ \rightarrow e^+ \gamma$: accidental background

$$N_{acc} \propto R_{\mu}^2 \cdot \Delta E_{\gamma}^2 \cdot \Delta p_e \cdot \Delta \theta_{e\gamma}^2 \cdot \Delta t_{e\gamma} \cdot T$$

→ γ energy measurement resolution is important for background suppression

- for γ measurement, pair spectrometer with active converter is under development

Pair spectrometer with active converter

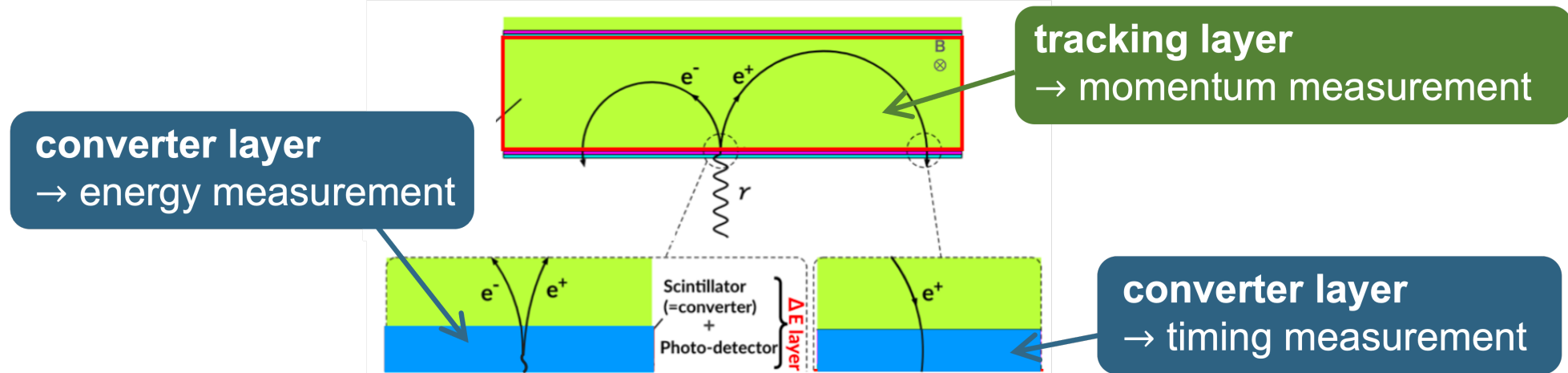

problem with conventional pair-spectrometer

- low efficiency (compared to calorimeter) → want to increase thickness
- energy loss in converter → want to reduce thickness

➔ solution : **energy measurement by converter (active converter)**

requirements for active converter

$\frac{\Delta E}{E} < 0.4 \%$ at signal region ($E = 52.8 \text{ MeV}$) & $\Delta t < 30 \text{ ps}$ for pair spectrometer

$N_{\text{p.e.}} > 670 \text{ p.e.}$ (3mm thickness converter) & $\Delta t < 40 \text{ ps}$ for 1 MIP

candidate material for active converter ... LYSO

Beamtest of active converter

- **Electron beam at KEK PF-AR Test beam line**

- Beam momentum ~ 3 GeV
- Beam rate ~ 4.5 kHz

- **Active converter prototype**

LYSO + SiPM readout (three on both edge)

- **Readout method**

- ① **independent readout**

- Three readout channels /side
- Timing is calculated from weighted average of channels

- ② **series readout**

- Three SiPMs connected in series
- One readout channel /side
- Small capacitance \rightarrow faster response

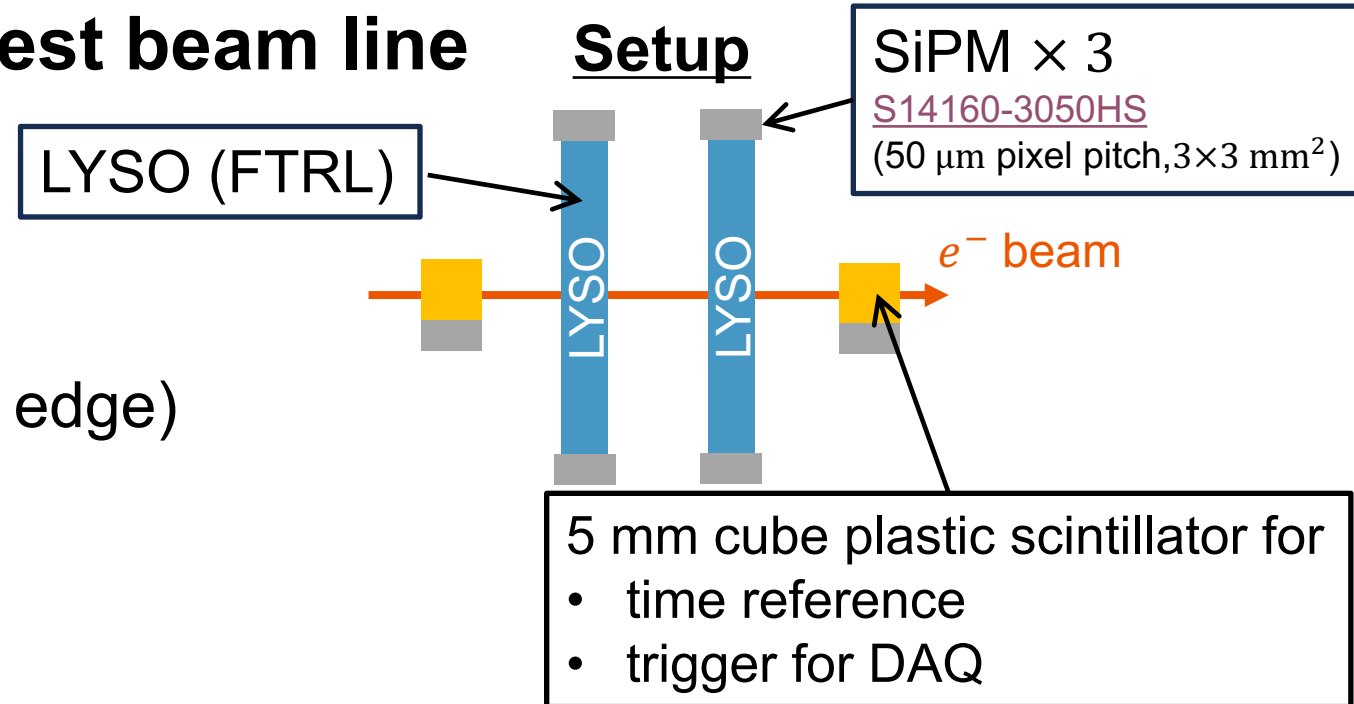

- preliminary analysis reported by R.Yokota (JPS 2024 spring, 19aT1-9)
- more detailed analysis in this study

studied item on the beamtest

① Performance comparison with various

- LYSO size
- readout method (independent/series)
- SiPM pixel pitch

② Performance dependence on

- Beam injection position
- Beam injection angle

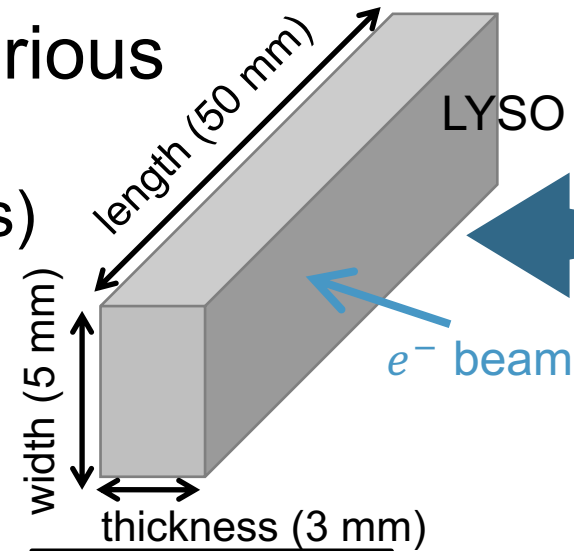

one segment
(standard size)

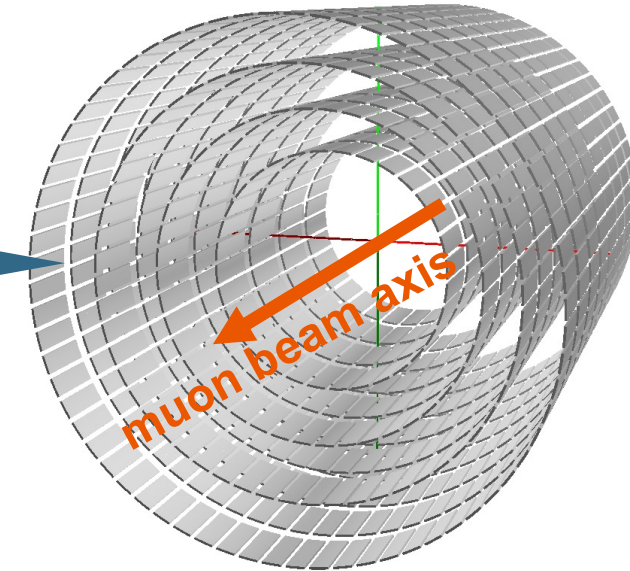

segmentation of converter
in the future experiment

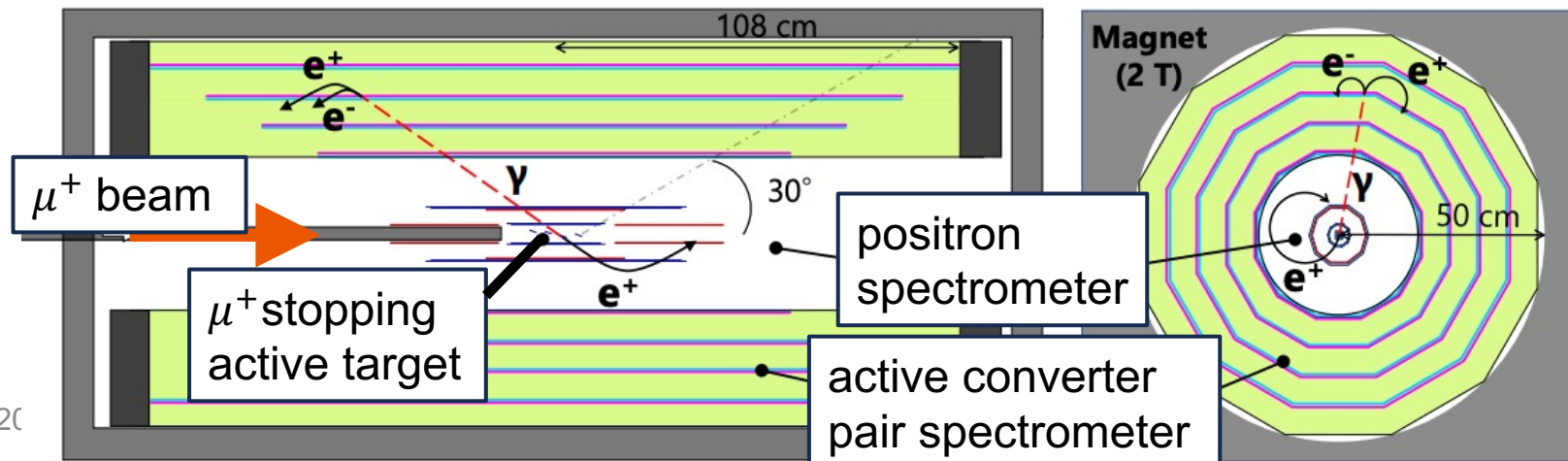

lightyield analysis

- 1 p.e. gain was calculated from dark count of MPPC
- Lightyield analysis was done with the low gain beam data
- **Lightyield was far beyond the target (670 p.e.)**

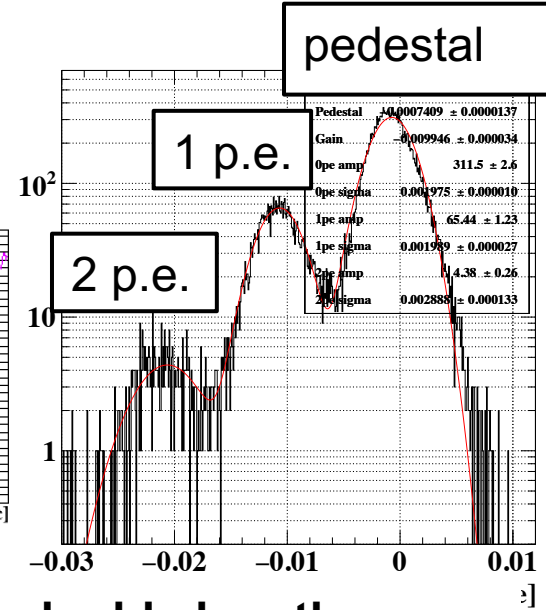
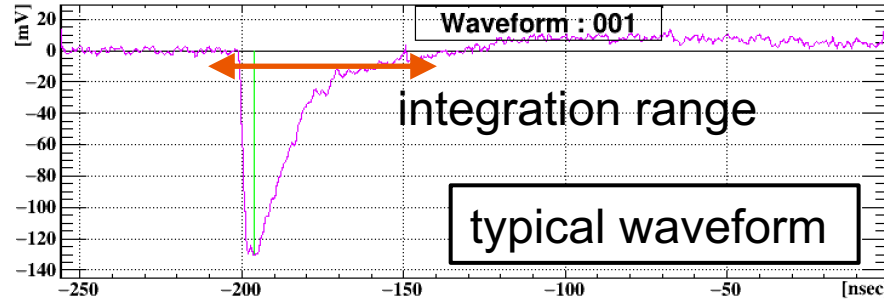

standard size
(3 mm×5 mm×50 mm)

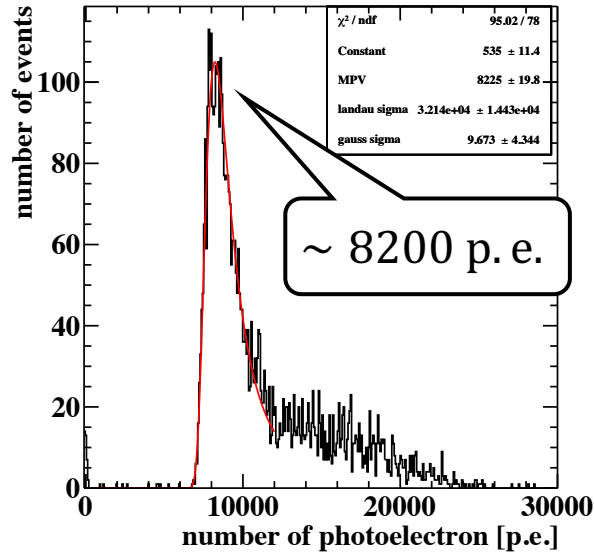

half thickness
(1.5 mm×5 mm×50 mm)

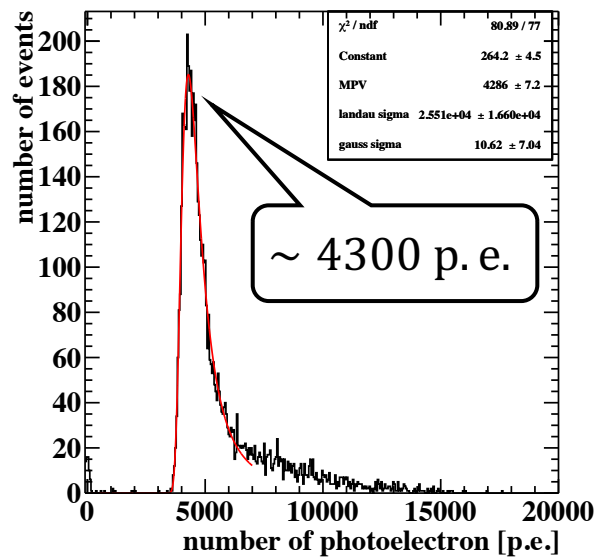

double width
(3 mm×10 mm×50 mm)

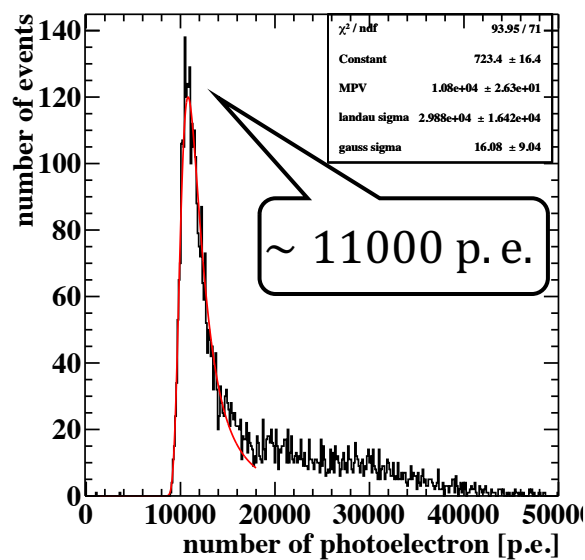

double length
(3 mm×5 mm×100 mm)

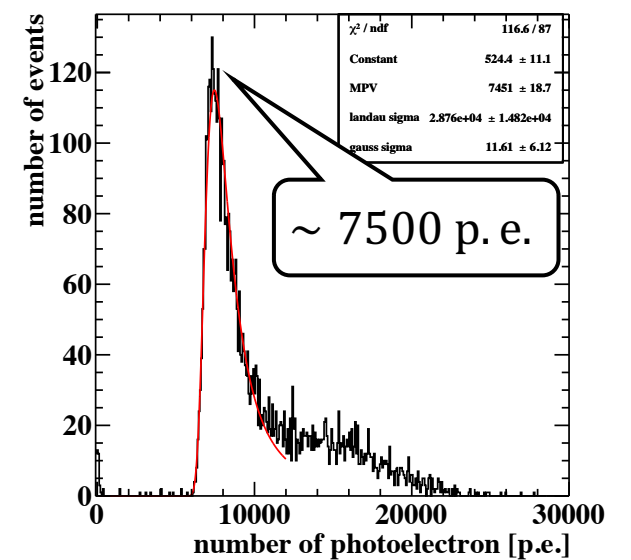

time resolution analysis method

- Operation in high gain (to focus on the early arrival photon)
- Time pick-up : leading edge method
- Time walk correction : using time over threshold

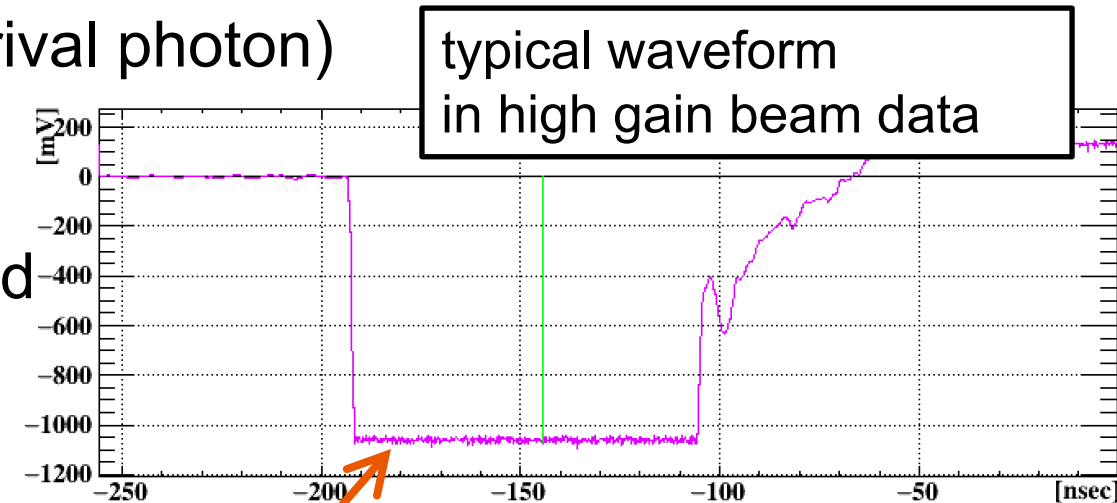
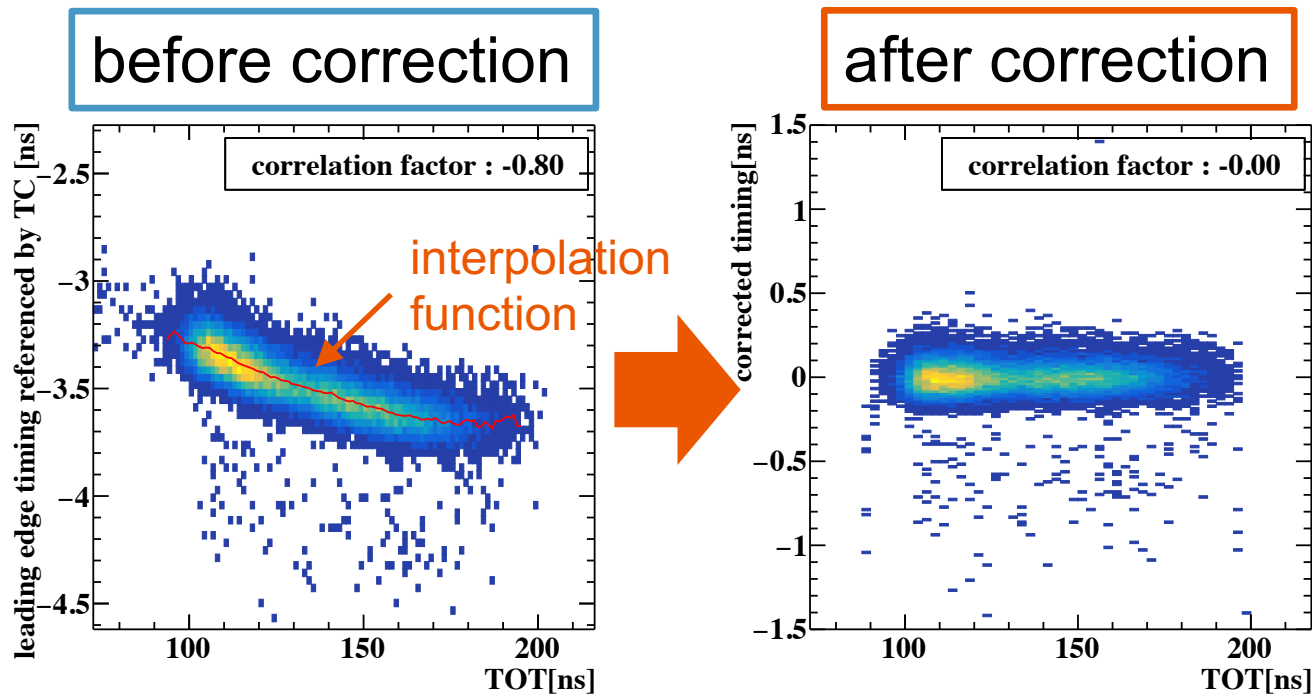

saturated waveform due to the dynamic range of electronics

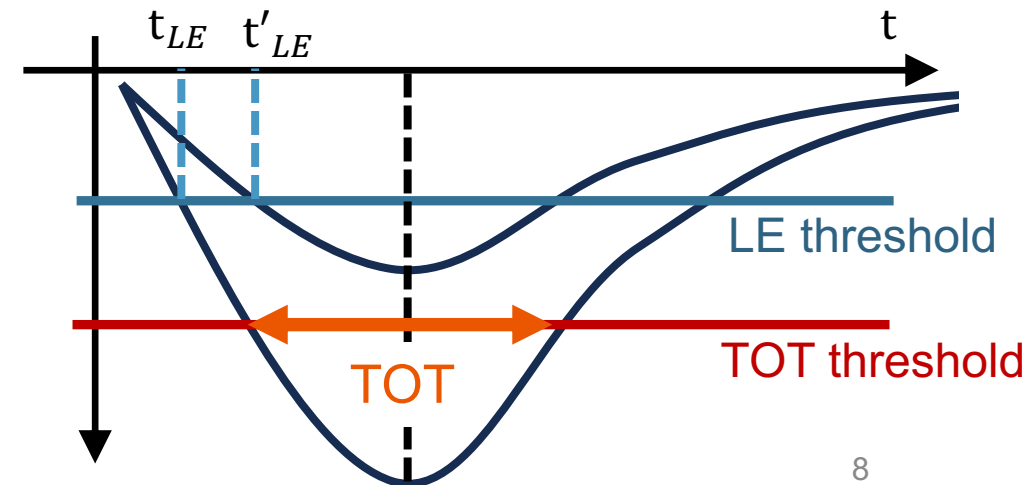

time resolution analysis result – LYSO size –

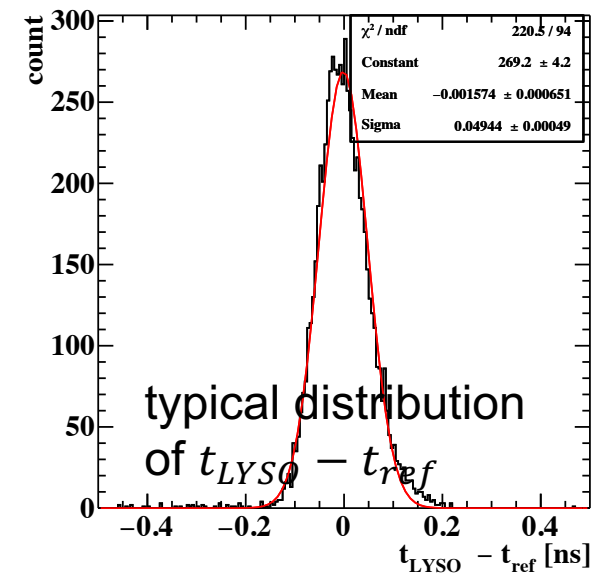

	Standard size (3 mm×5 mm×50 mm)	Half thickness (1.5 mm×5 mm×50 mm)	Double width (1.5 mm×5 mm×50 mm)	Double length (3 mm×5 mm×100 mm)
Independent readout	27.0 ps	36.1 ps	26.5 ps	30.4 ps
Series readout	29.4 ps	(no data taken)	27.6 ps	(no data taken)

- Basically, LYSO size that had larger lightyield has better time resolution
- Independent readout has slightly better resolution by a few ps
 - This is due to the difference in the **remaining time walk effect** after correction
- Correlation between timing of left channels and right channels → ...stronger on series connection

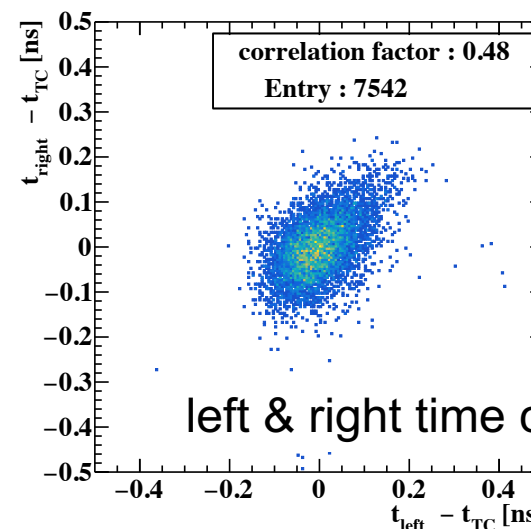

independent connection

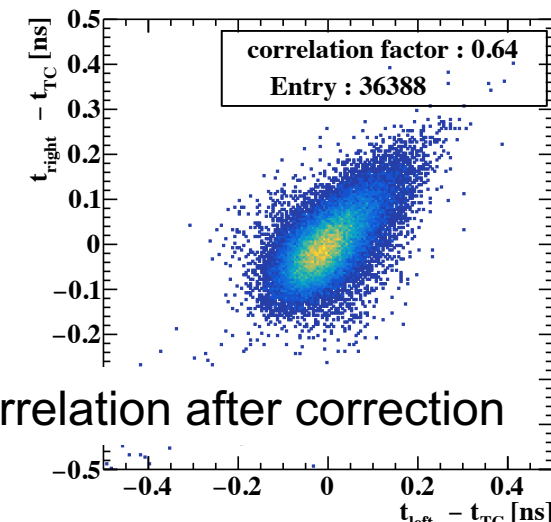

series connection

time resolution analysis result – angle dependence –

injection angle scan
(1.5 mm thickness LYSO)

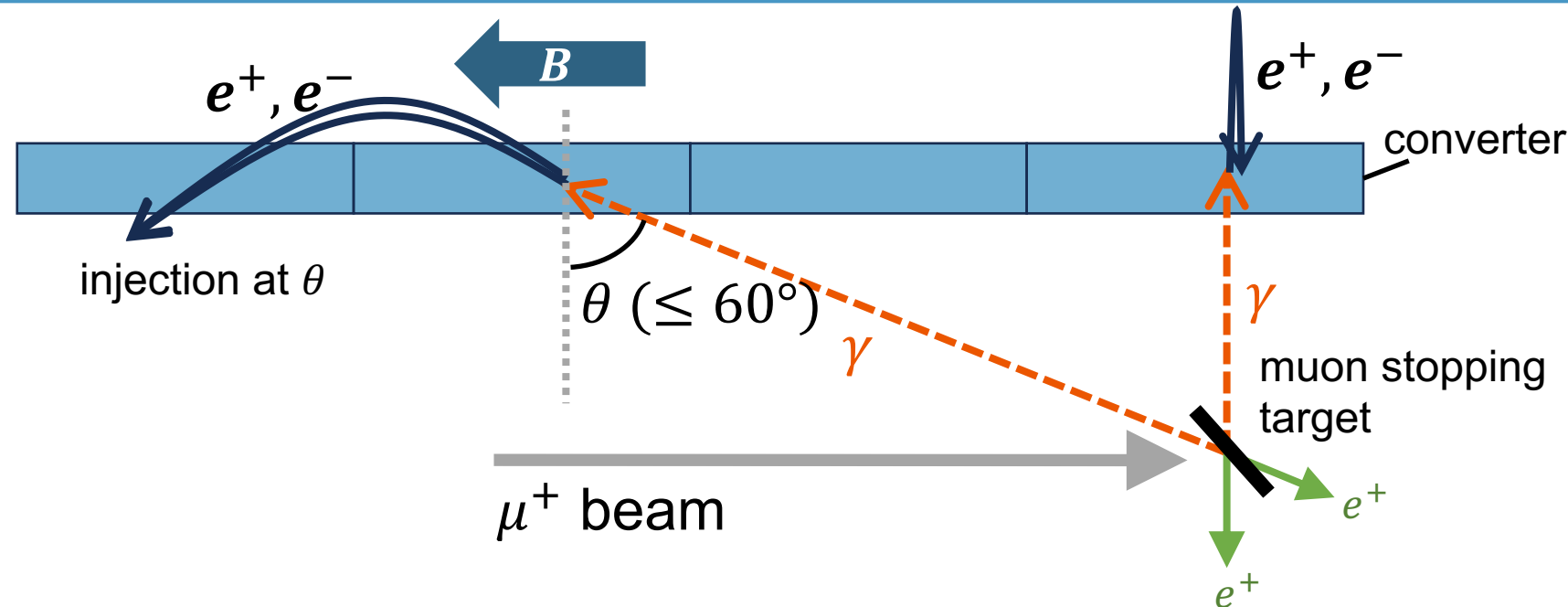
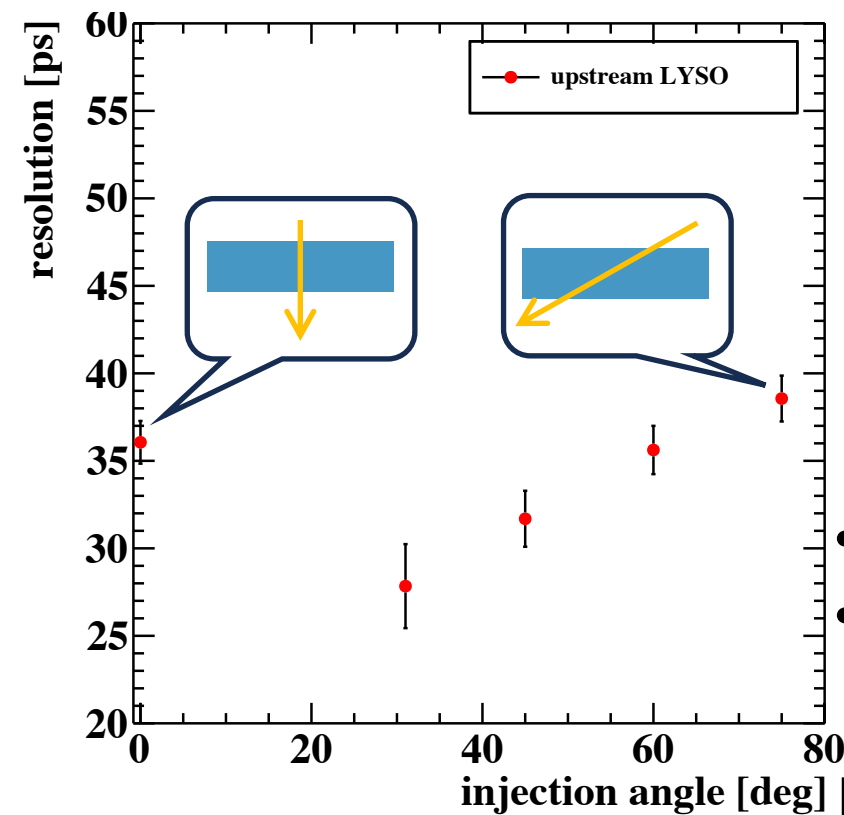

- Injection angle will be steeper in the outer segments
 - Steeper incident has longer effective thickness
- ➔ Outer converter should be thinner

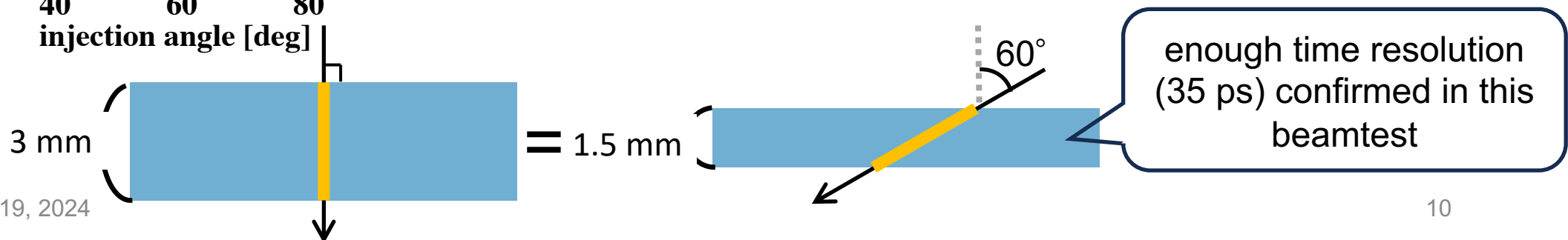

time resolution analysis result – position dependence –

Except the injection on the most edge,
LYSO achieved the goal resolution of 40 ps
with all injection position

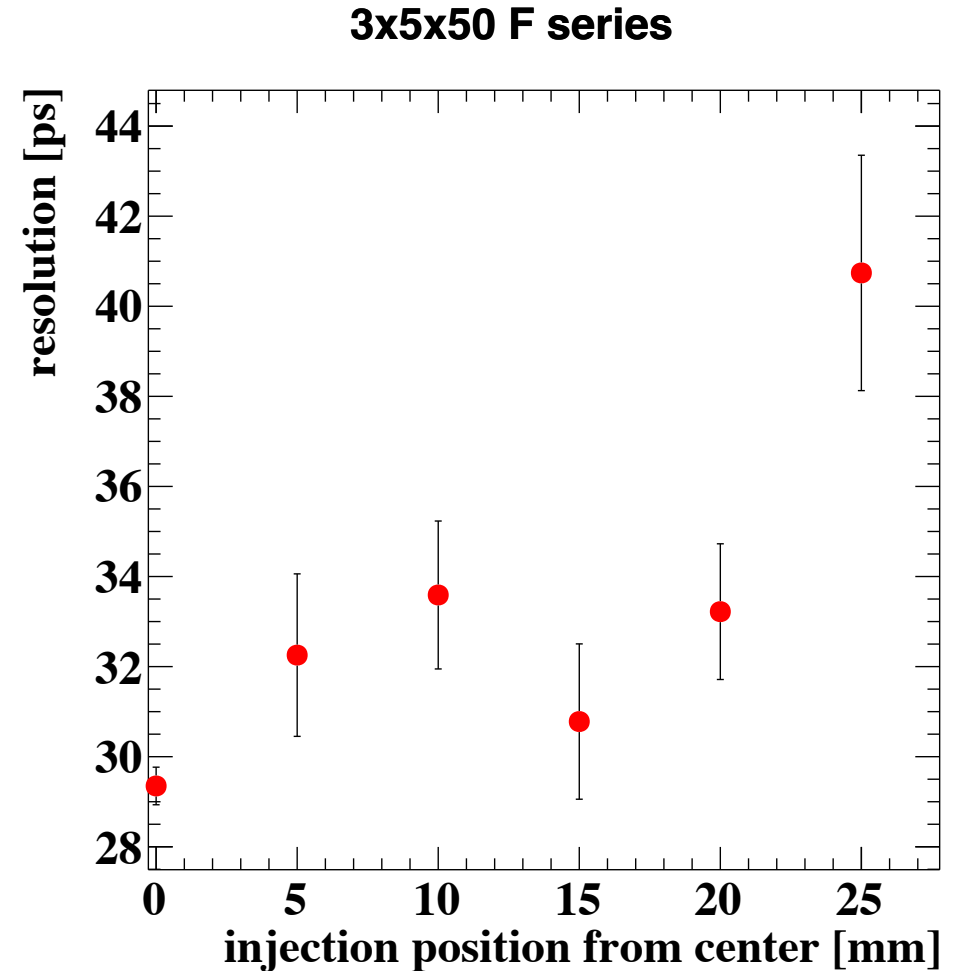
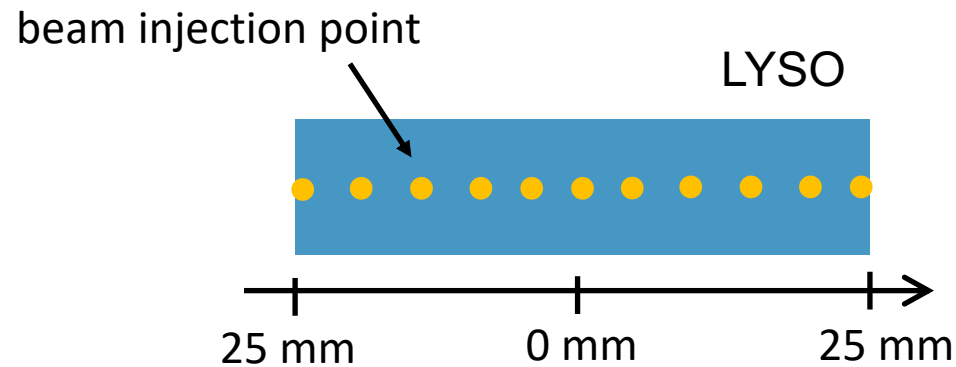

time resolution analysis result – pixel pitch comparison–

- Tested MPPCs with different pixel pitch
 - 10 μm ([S14160-3010PS](#))
 - 15 μm ([S14160-3015PS](#))
 - 50 μm ([S14160-3050HS](#))
- 50 μm pixel pitch shows the best performance because of
 - high gain
 - high PDE

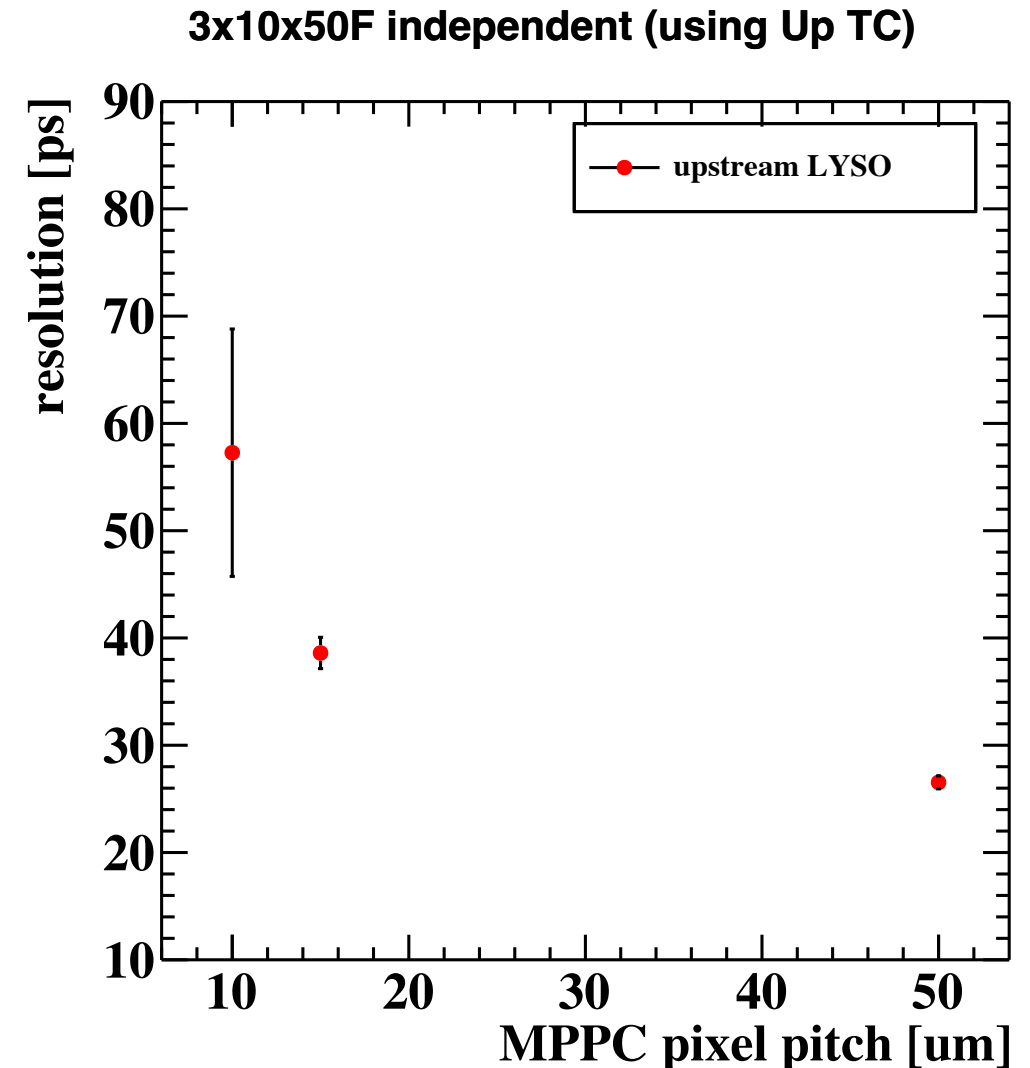

summary and prospect

summary

- **Pair spectrometer with active converter** is under R&D as a gamma detector for the future experiment for $\mu^+ \rightarrow e^+ \gamma$ decay search.
- The beamtest result shows that **requirement of energy and time resolution for a converter can be well achieved with LYSO**.
- Active converter with **3 mm × 10 mm × 50 mm LYSO** and **50 μm pixel pitch MPPC** had the best performance in terms of energy & time resolution.

prospect

- Remaining time walk effect was seen even after the correction by TOT
→ improve correction by the charge information
- In the future experiment, timing and energy must be measured at the same time

 Beam test with high gain & low gain DAQ at the same time in Nov.-Dec. 2024

backup

KEK PF-AR test beam line

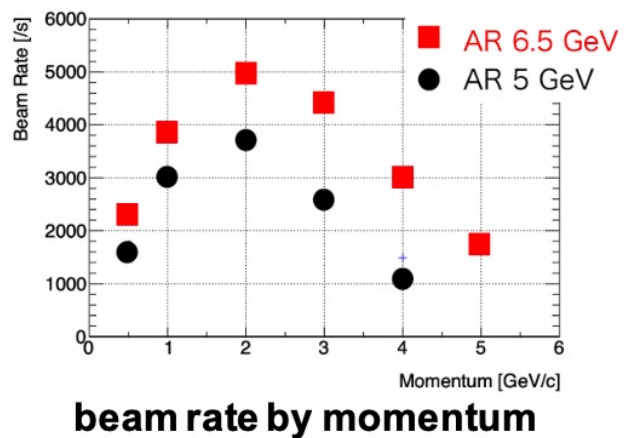
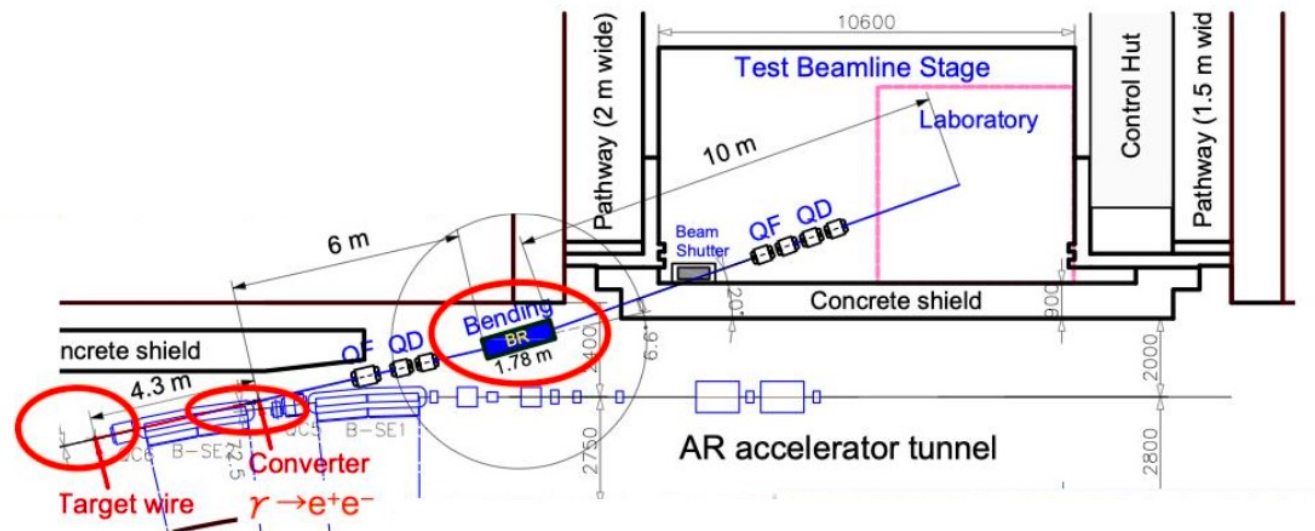

Beam Size at focal point at beam stage

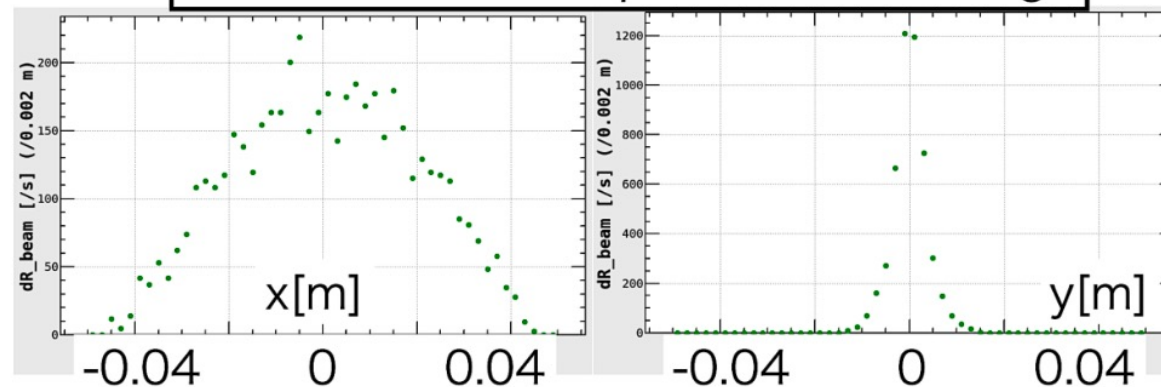

requirements for the active converter

energy resolution

- $\frac{\Delta E}{E} \leq 0.4 \% @ E = 52.8 \text{ MeV}$ for pair spectrometer
→ $\Delta E \leq 211 \text{ keV}$ for 2 MIP(e^+ & e^-)
- deposit energy of 2 MIP:
 $E' = 1.12 \text{ MeV/mm} \times 3 \text{ mm} \times 2 = 6.72 \text{ MeV}$ (in 3 mm thickness LYSO)
→ $\frac{\Delta E}{E'} = \frac{1}{\sqrt{N_{\text{p.e.}}}} \leq \frac{211 \text{ keV}}{6.72 \text{ MeV}} = 2.73 \%$
→ $N_{\text{p.e.}} \geq 1341$ for 2 MIP
→ $N_{\text{p.e.}} \geq 671$ for 1 MIP

time resolution

- $\Delta t = 30 \text{ ps}$ for pair spectrometer → $30 \times \sqrt{2} = 42 \text{ ps}$ for 1 MIP

deposit energy by electron in different energy

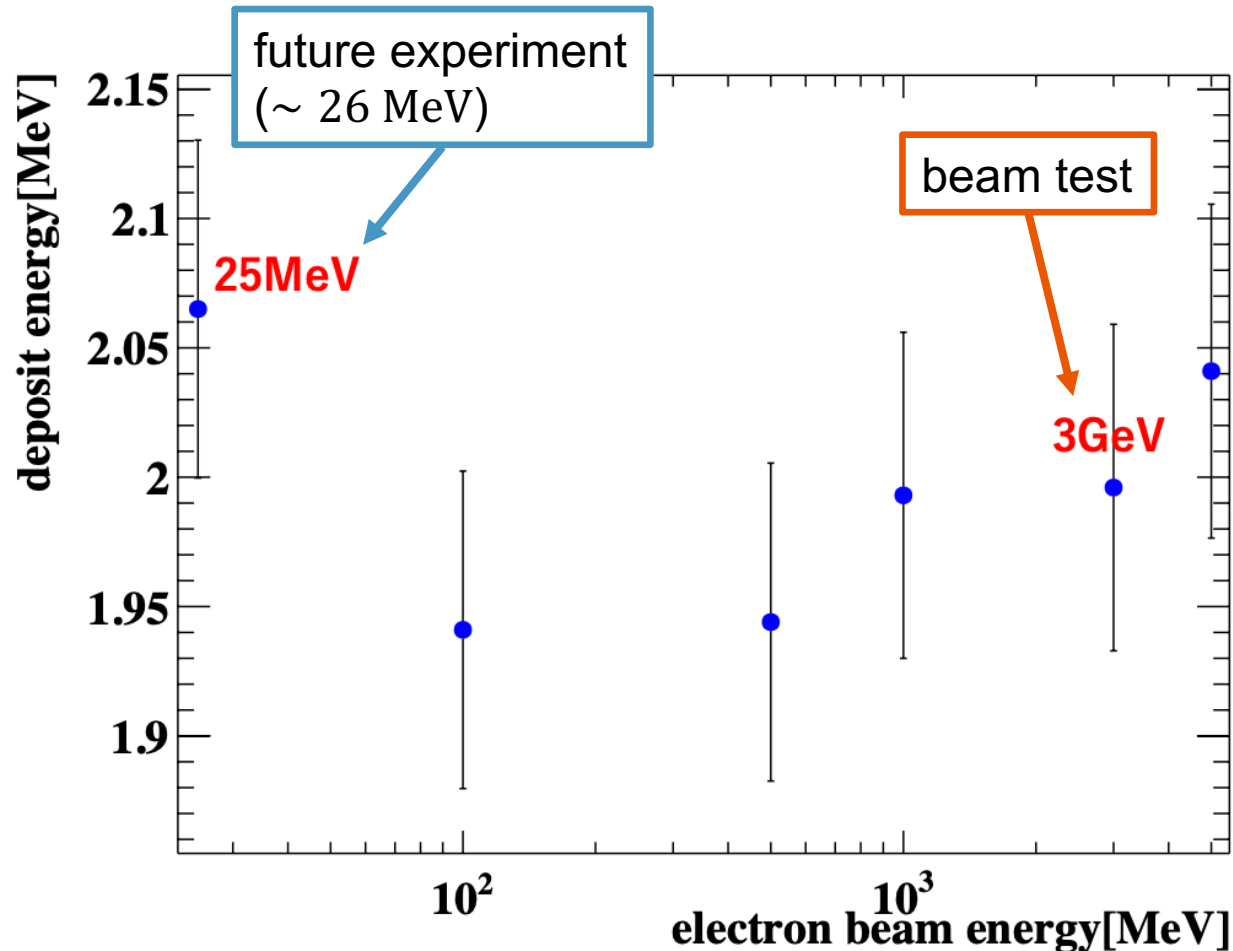

(R.Yokota, 2023 thesis)

- deposit energy in LYSO was simulated with various electron beam energies
- deposit energy in LYSO of 3 GeV electron was almost identical to that of 25 GeV electron



the resolution obtained in the beam test could be applied to the future experiment

lightyield analysis method

1. estimate 1 p.e. gain with the dark count of MPPC
2. obtain charge from the low gain beam where full waveform is recorded
3. estimate the detected number of photoelectrons at LYSO by

$$N_{p.e.} = \sum_{i=\text{MPPC channels}} \frac{(\text{ch } i \text{ charge})}{(\text{ch } i \text{ 1 p.e. gain})}$$

upstream LYSO lightyield (run197)

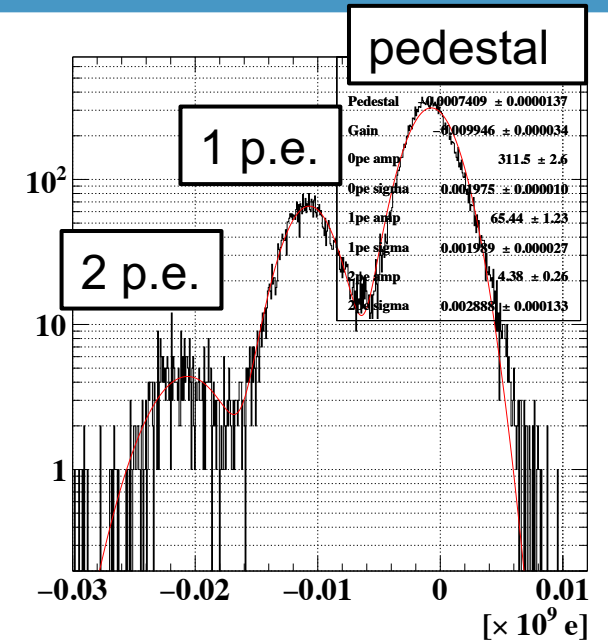
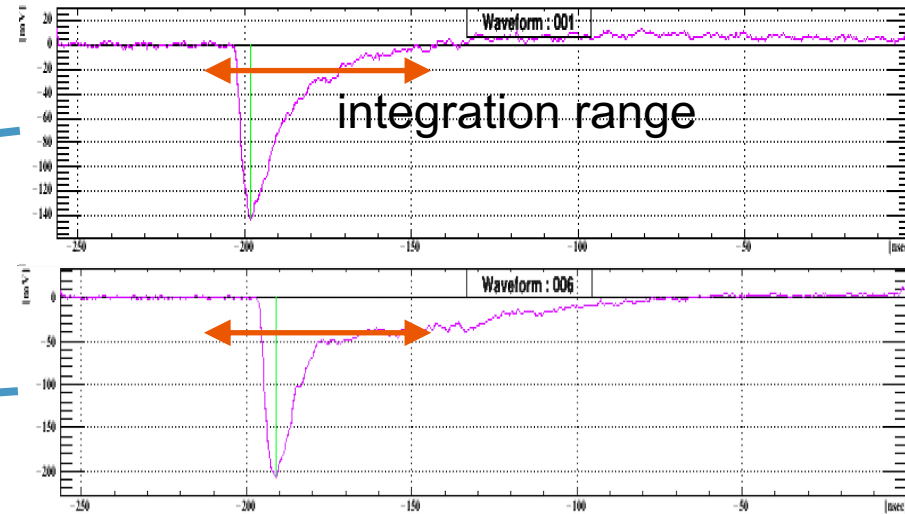
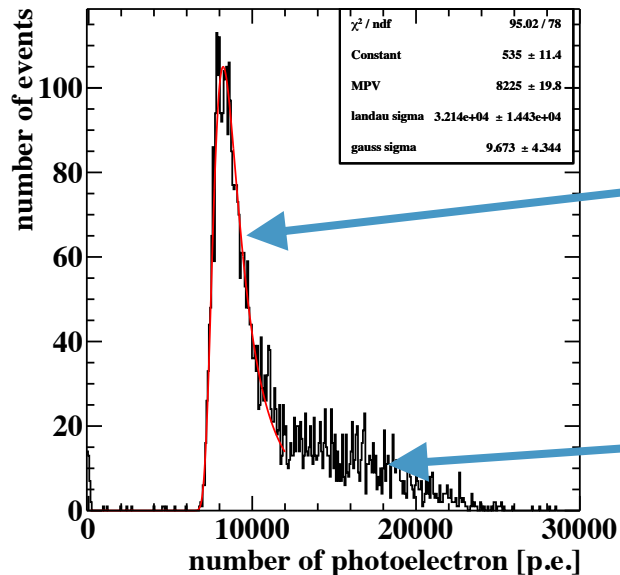

lightyield analysis result

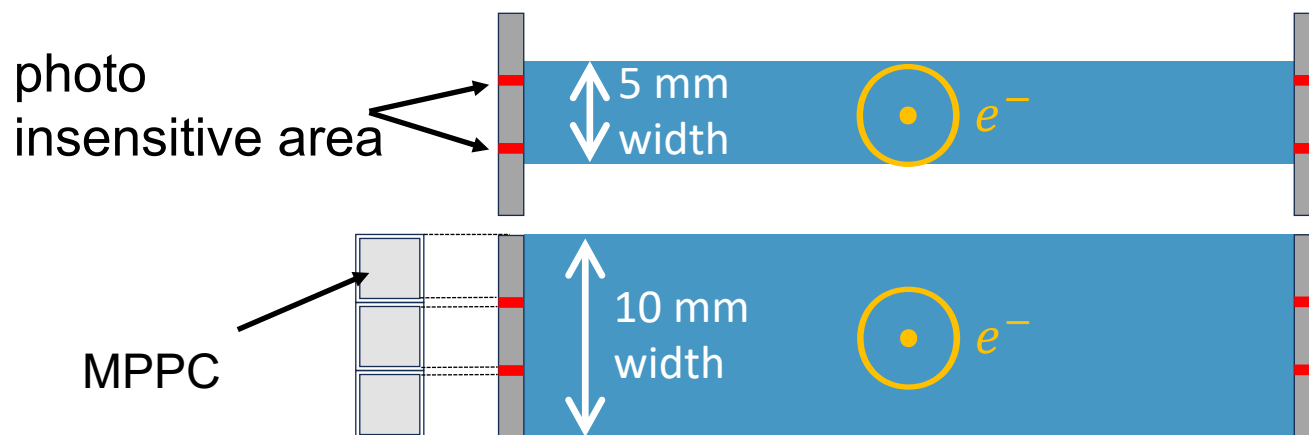
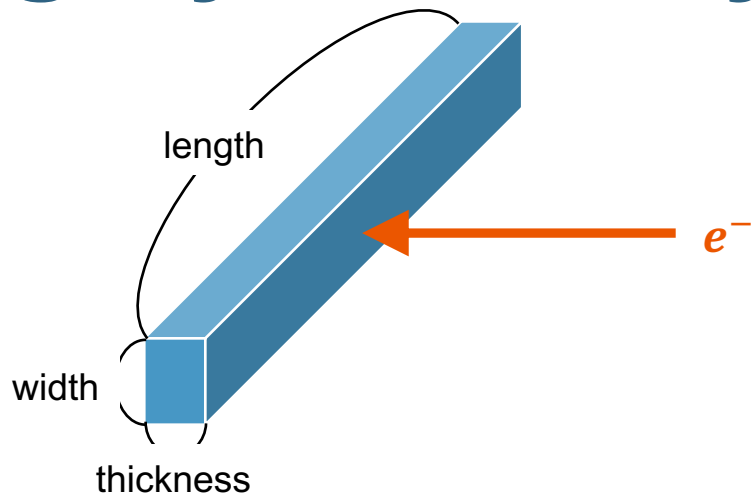

LYSO size	Standard (3mm x 5mm x 50mm)	Half thickness	Double width	Double length
Lightyield [p.e.]	8344 ± 22	4345 ± 9	10900 ± 29	7564 ± 20

- thickness : lightyield decreases in proportion to the thickness
- width : wider LYSO have smaller ratio of photo-insensitive area
- length : longer LYSO is more susceptible to the attenuation of scintillation light

LYSO of all size achieved the goal of $N_{p.e.} > 670$

($N_{p.e.} > 168$ for half thickness)

time walk correction

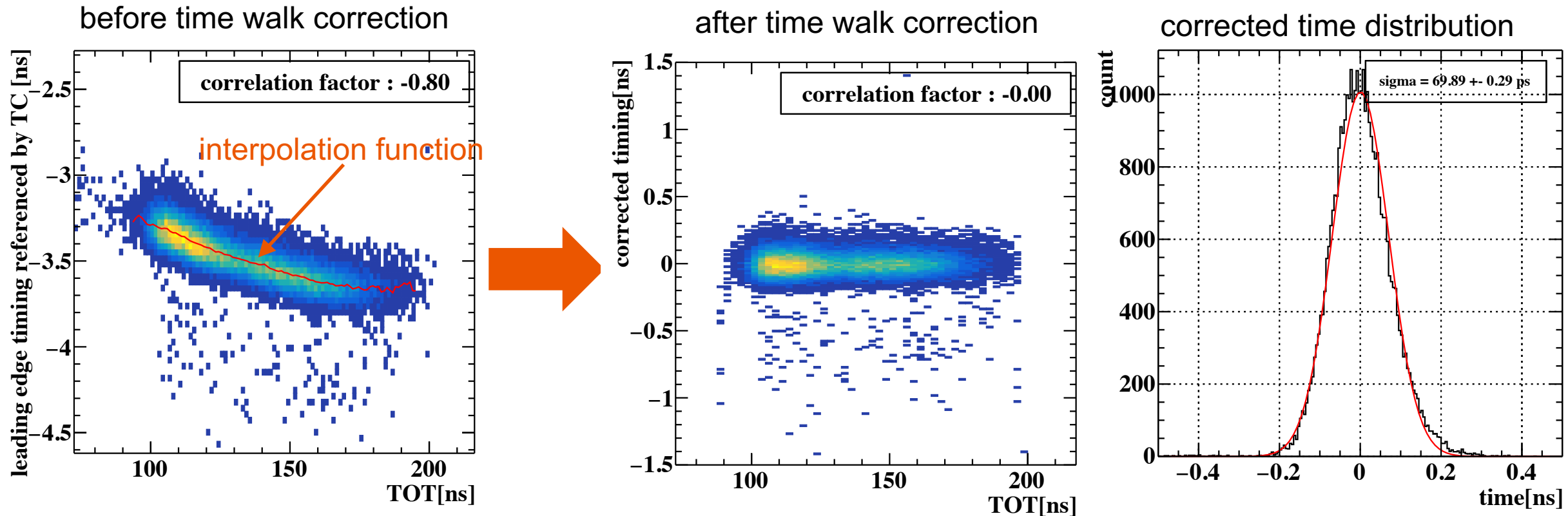

1. look at the correlation between $t_{LE} - t_{ref}$ and TOT, and get the interpolation function
2. subtract interpolation function from the datapoint
3. obtain resolution from a σ of a gaussian fit of corrected time

optimization of the thresholds

thresholds to be optimized:

1. leading edge threshold for each LYSO channel
2. TOT threshold for each LYSO channel
3. leading edge threshold for time reference counter

LE threshold scan

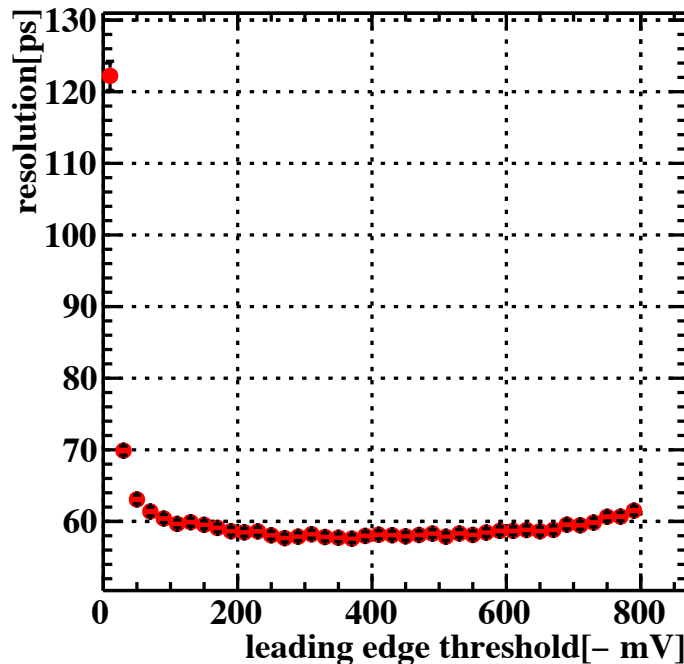

TOT threshold scan

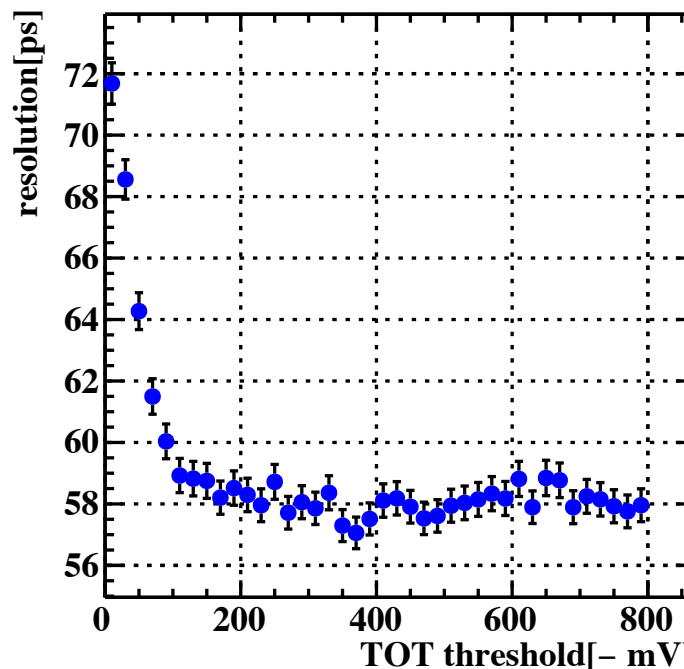

LE threshold scan
for reference TC

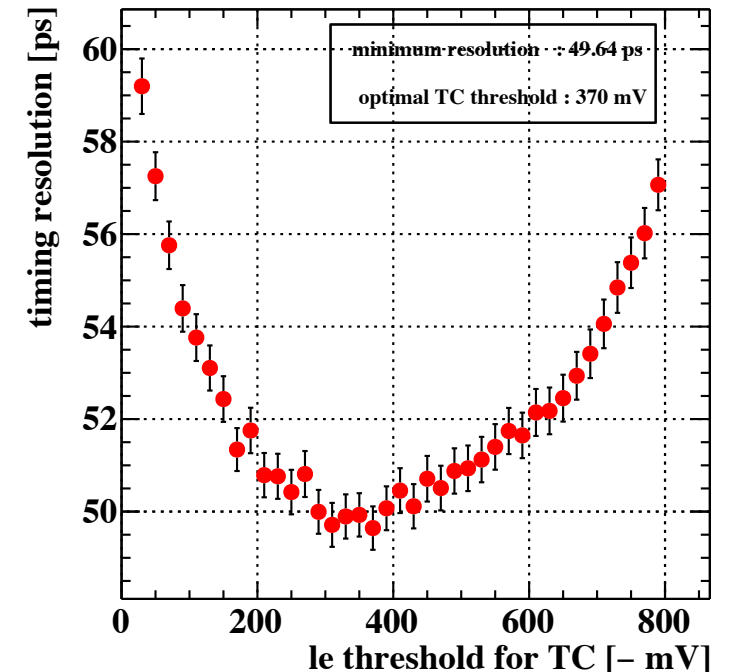

timing decision by multiple MPPC channels

- asymmetry in lightyield in 3 channels(independent connection)
→decide timing of LYSO by the weighted average of MPPC channels

- weight $\propto 1/\sigma_i^2$
(σ_i : time resolution of 1 MPPC channel)

$$t_{\text{LYSO}} - t_{\text{ref}} = \sum_{\text{channels}} w_i (t_i - t_{\text{ref}})$$

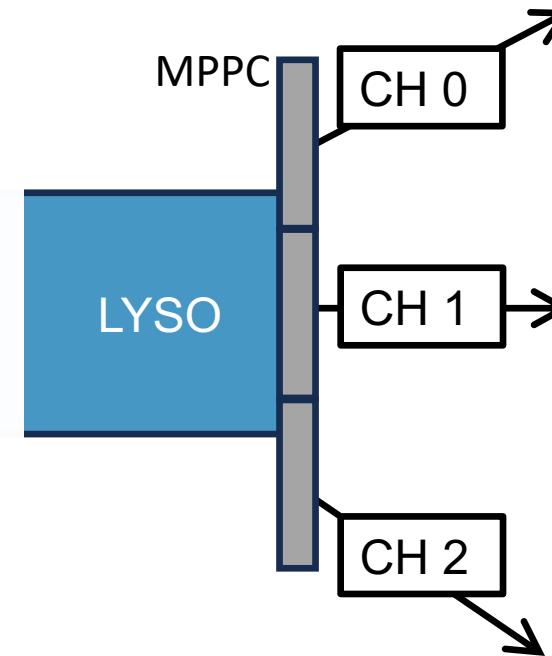

center MPPC channels (larger p.e.) are weighted more than the edge MPPC channels (smaller p.e.)

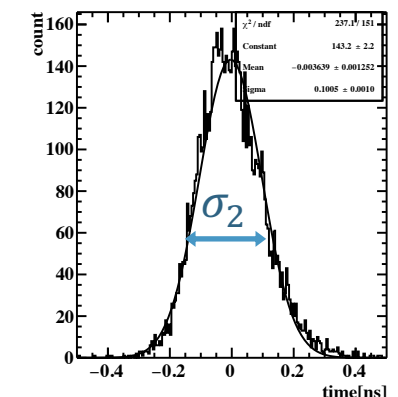
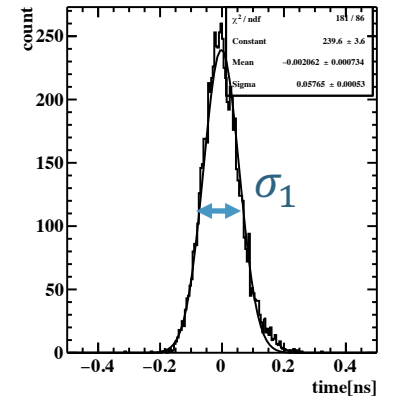
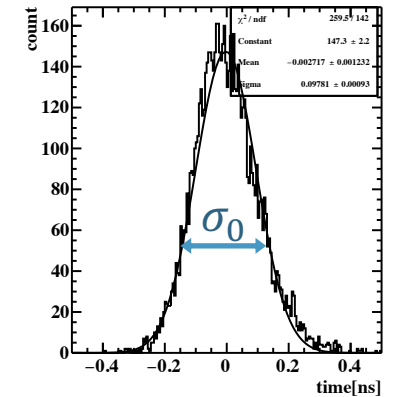

estimation of contribution from reference counter

$$\sigma(t_{\text{UpLYSO}} - t_{\text{ref}}) = \sqrt{\sigma_{\text{UpLYSO}}^2 + \sigma_{\text{ref}}^2}$$

$$\sigma(t_{\text{DownLYSO}} - t_{\text{ref}}) = \sqrt{\sigma_{\text{DownLYSO}}^2 + \sigma_{\text{ref}}^2}$$

$$\sigma(t_{\text{UpLYSO}} - t_{\text{DownLYSO}}) = \sqrt{\sigma_{\text{UpLYSO}}^2 + \sigma_{\text{DownLYSO}}^2}$$

able to calculate each σ_{UpLYSO} , σ_{DownLYSO} and σ_{ref}

$$(t_{\text{UpLYSO}} - t_{\text{ref}}) - (t_{\text{DownLYSO}} - t_{\text{ref}})$$

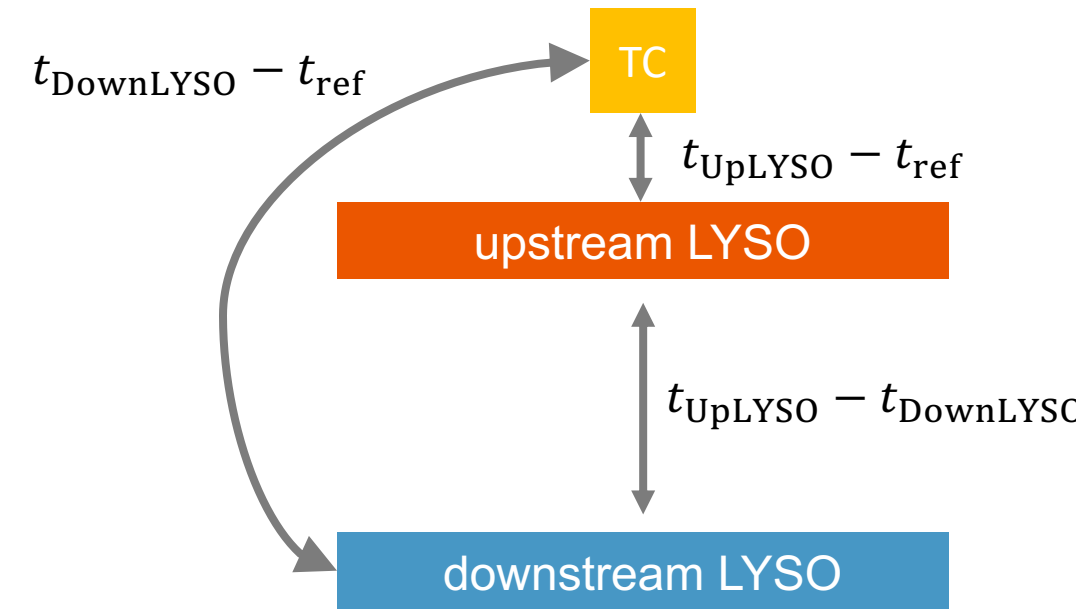
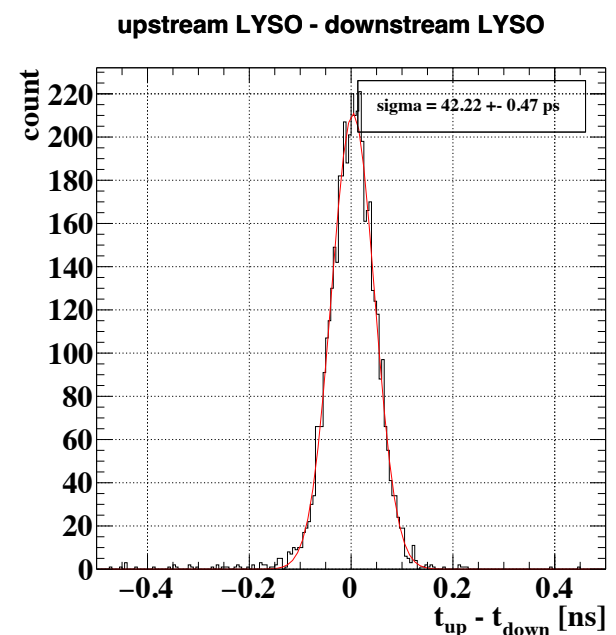

remaining time walk effect

independent connection

before correction

after correction

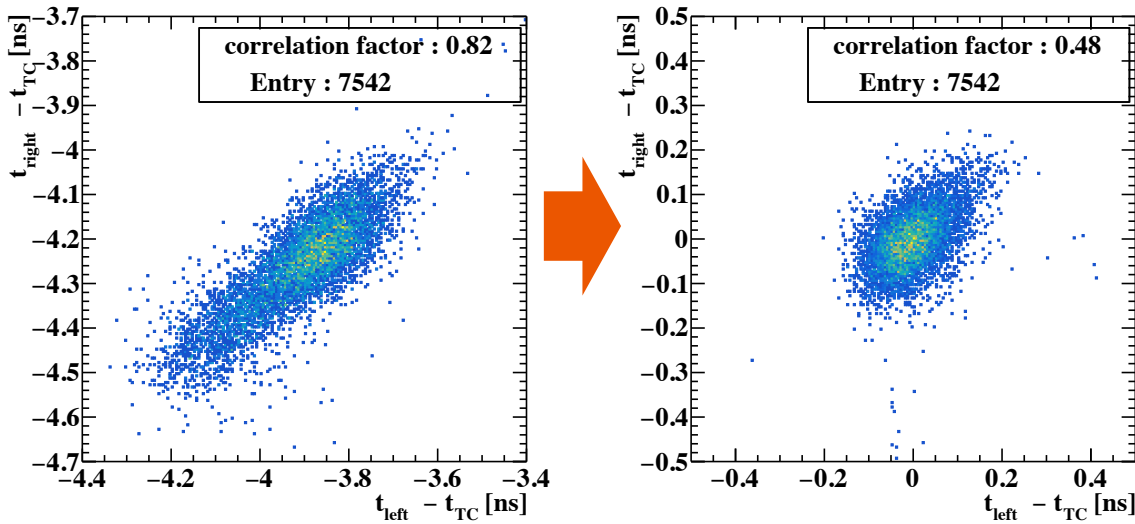

series connection

before correction

after correction

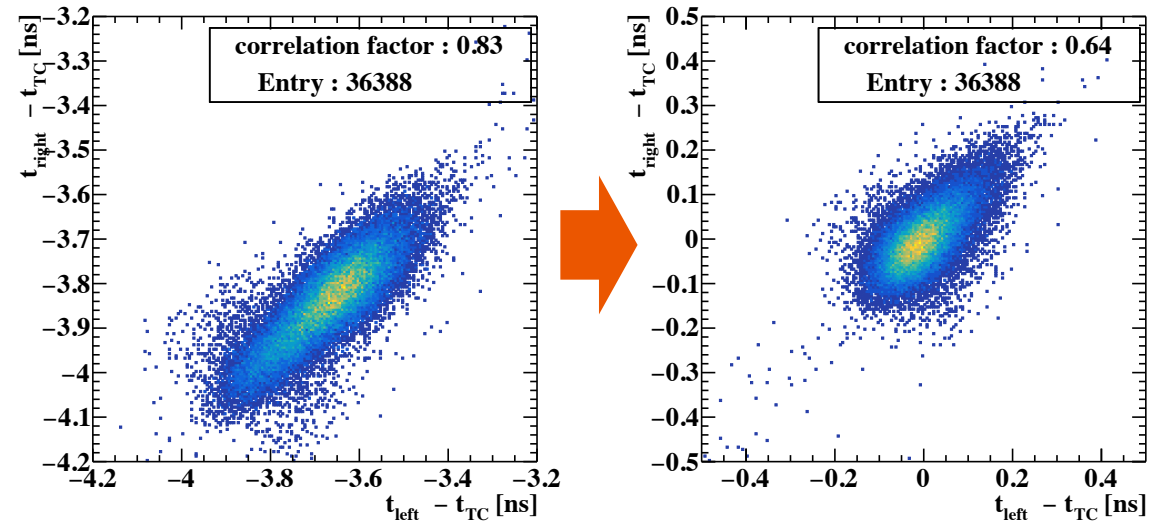

- if the time walk effect exists, t_{left} and t_{right} will correlate stronger

larger lightyield \rightarrow faster timing
 smaller lightyield \rightarrow slower timing
 } in both sides

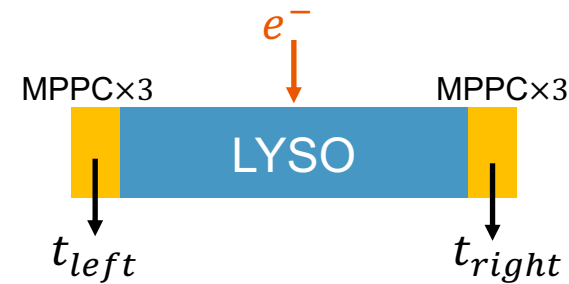

- series connection had stronger time walk effect left even after the correction by TOT

time resolution analysis result – angular dependence –

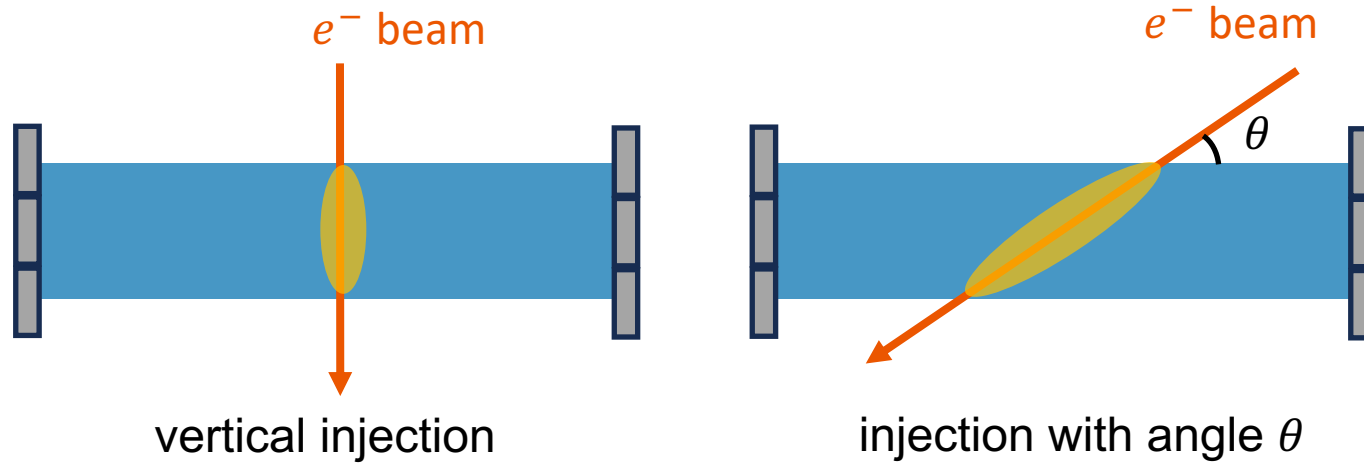

- steeper injection angle event has
 - more lightyield
→ improve time resolution
 - larger expansion in photon emission region
→ worsen time resolution

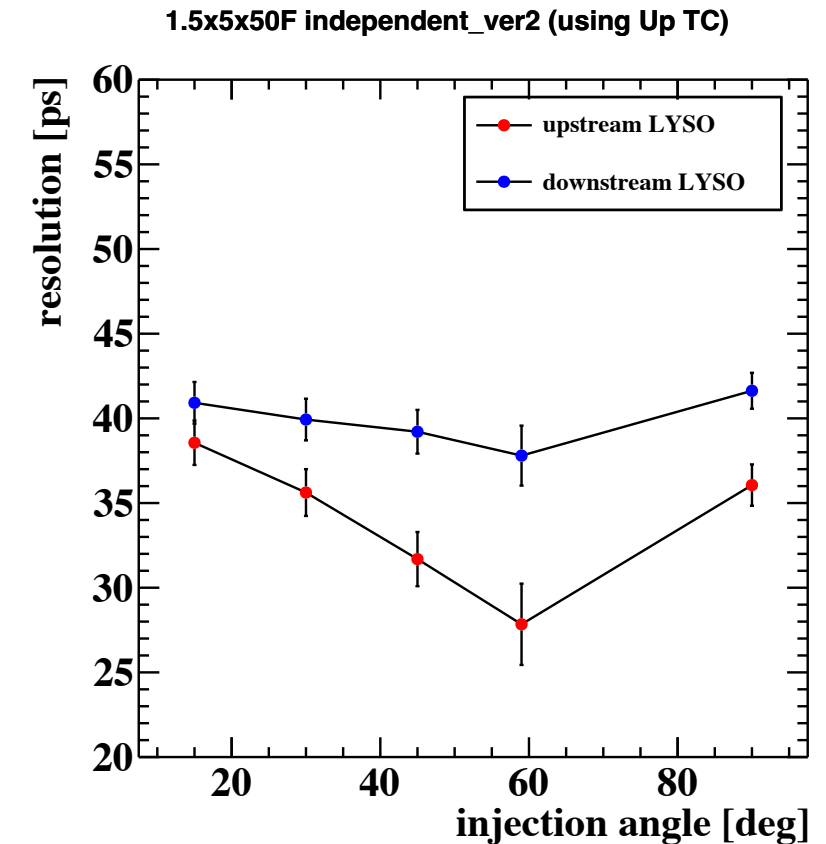

LYSO achieved the goal resolution of 42 ps with all injection angle

3 x 5 x 50 F&N (independent) position scan

3x5x50FN independent (using Up TC)

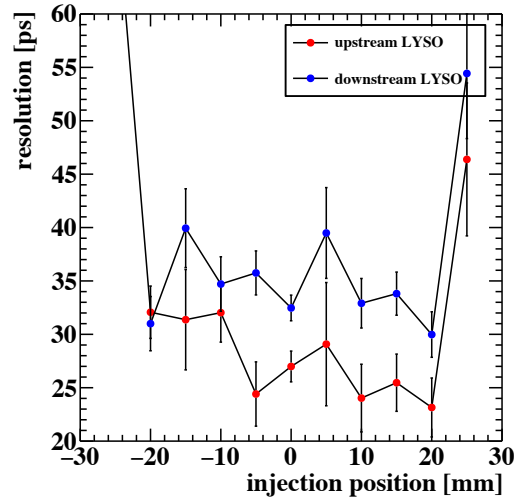

3x5x50FN independent

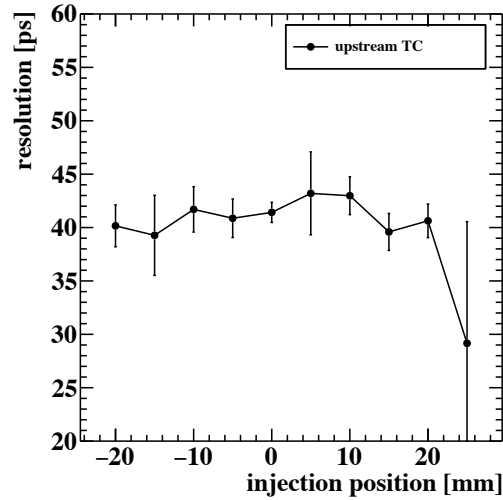

3x5x50FN independent upLYSO upTC

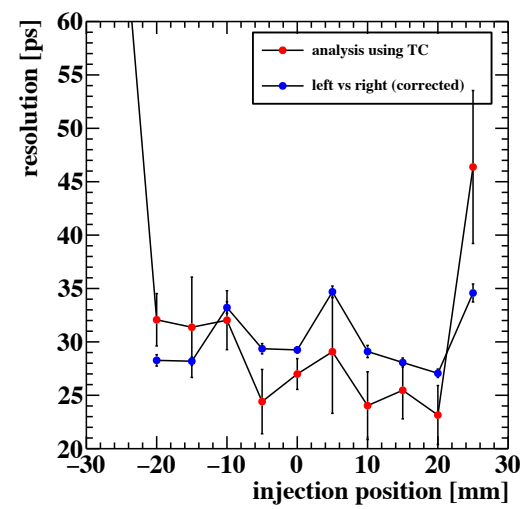

3x5x50FN independent upLYSO downTC

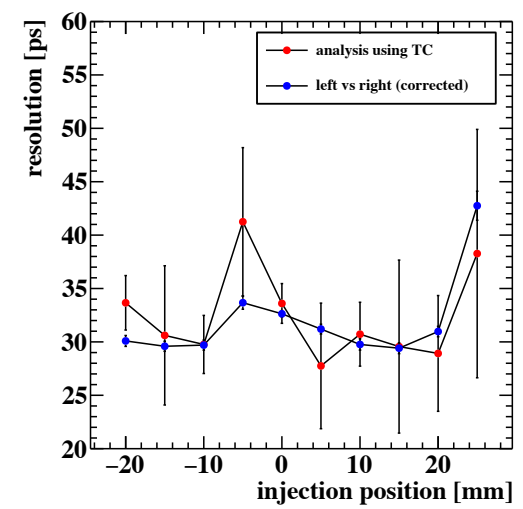

3x5x50FN independent (using down TC)

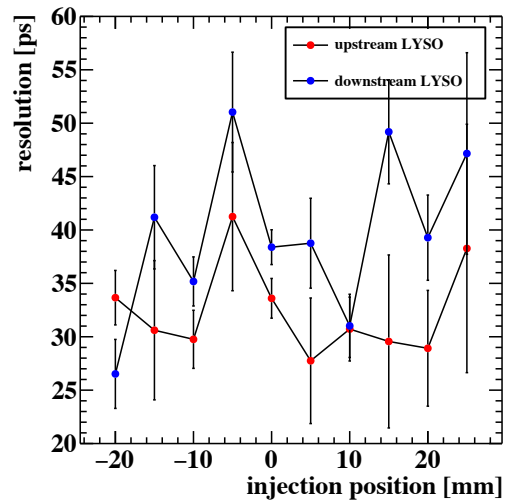

3x5x50FN independent

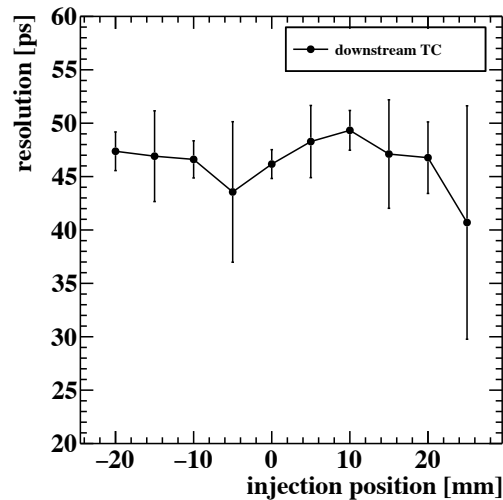

3x5x50FN independent downLYSO upTC

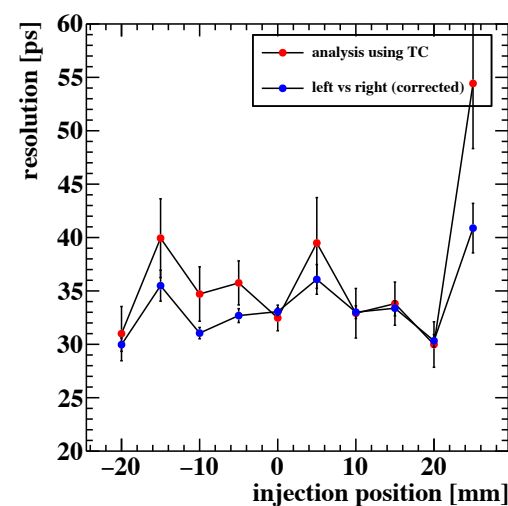

3x5x50FN independent downLYSO downTC

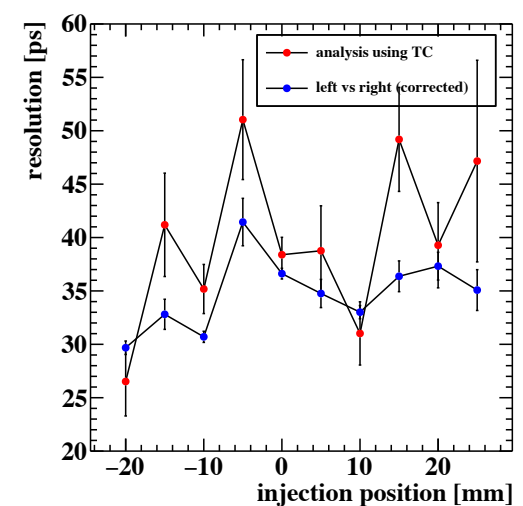

3 x 5 x 50 F (series) position scan

3x5x50F series (using Up TC)

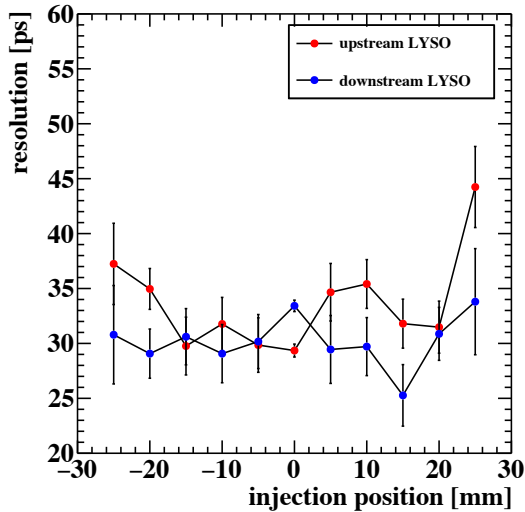

3x5x50F series

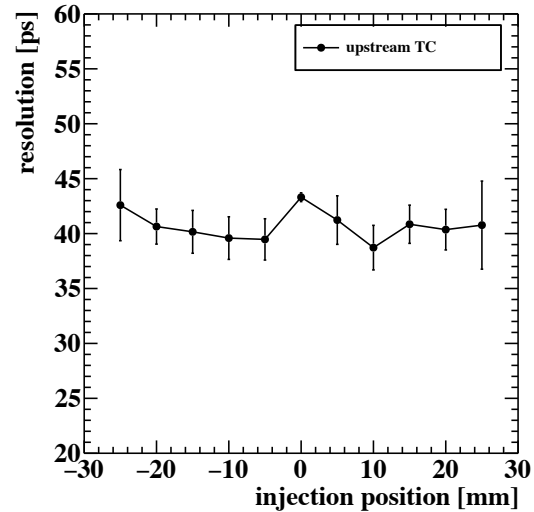

3x5x50F series upLYSO upTC

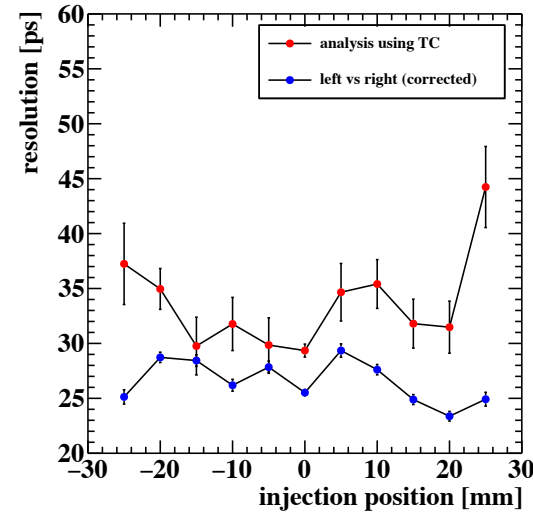

3x5x50F series upLYSO downTC

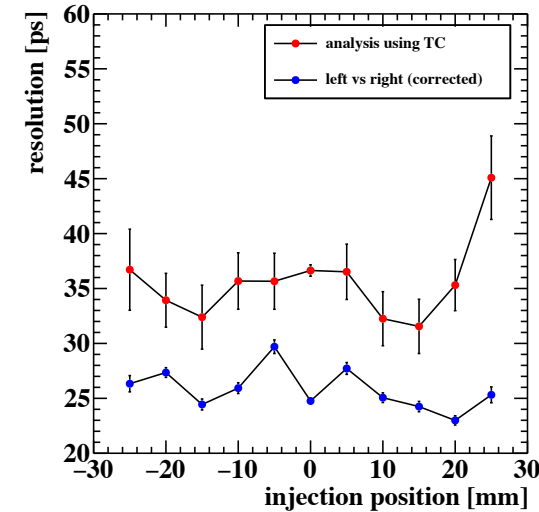

3x5x50F series (using down TC)

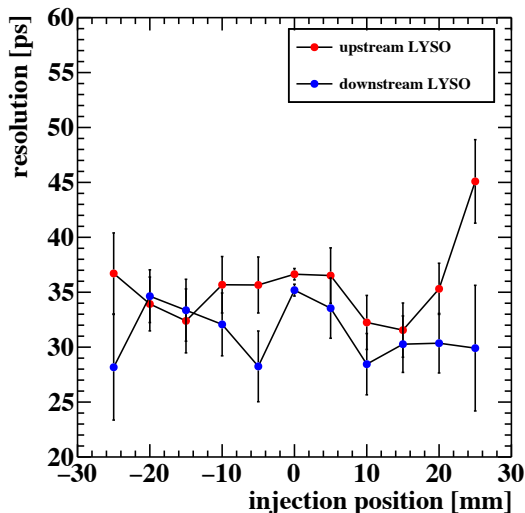

3x5x50F series

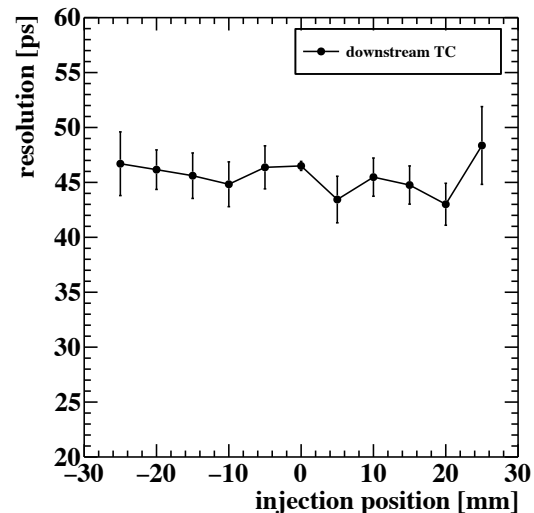

3x5x50F series downLYSO upTC

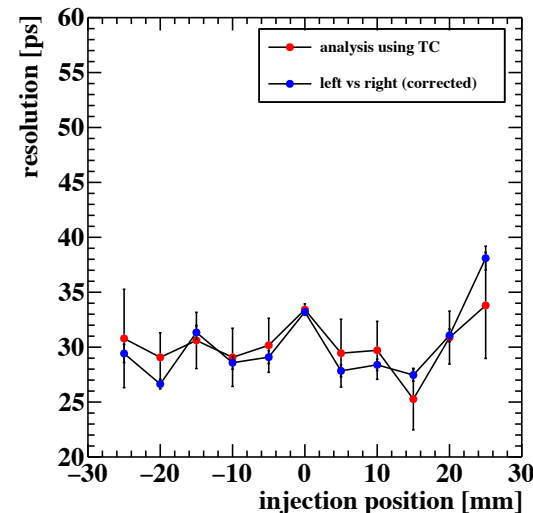

3x5x50F series downLYSO downTC

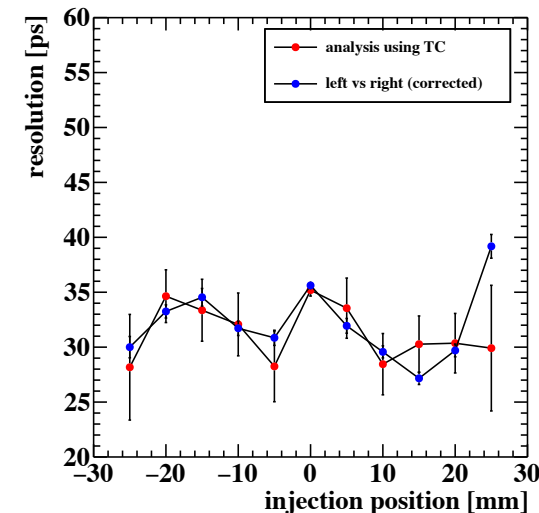

1.5 x 5 x 50 (independent) position scan

1.5x5x50F independent_ver2 (using Up TC)

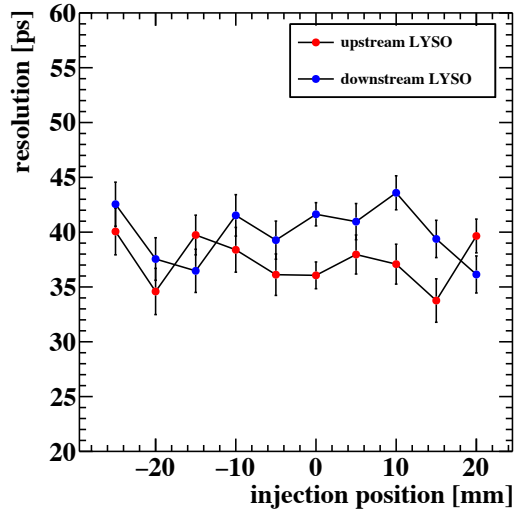

1.5x5x50F independent_ver2

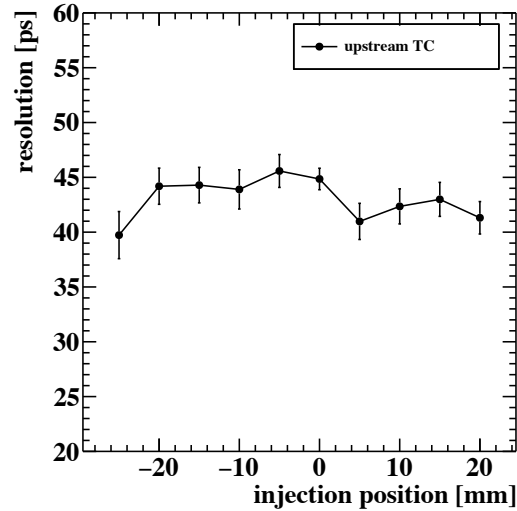

1.5x5x50F independent_ver2 upLYSO upTC

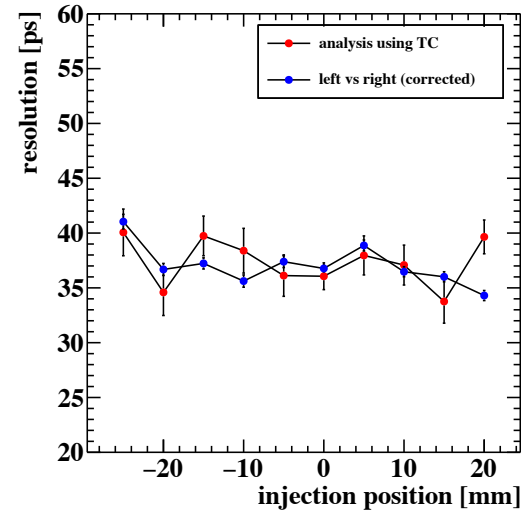

1.5x5x50F independent_ver2 upLYSO downTC

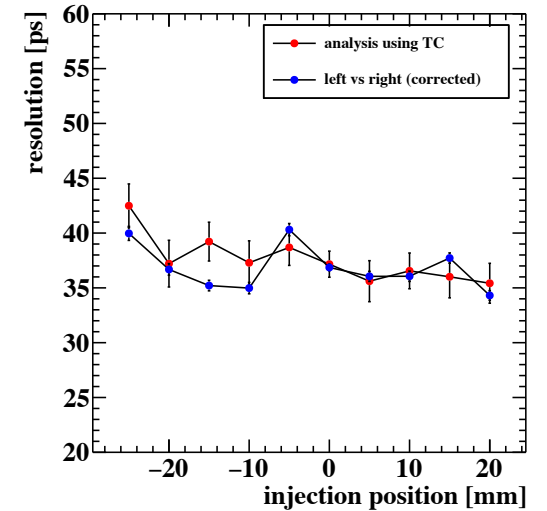

1.5x5x50F independent_ver2 (using down TC)

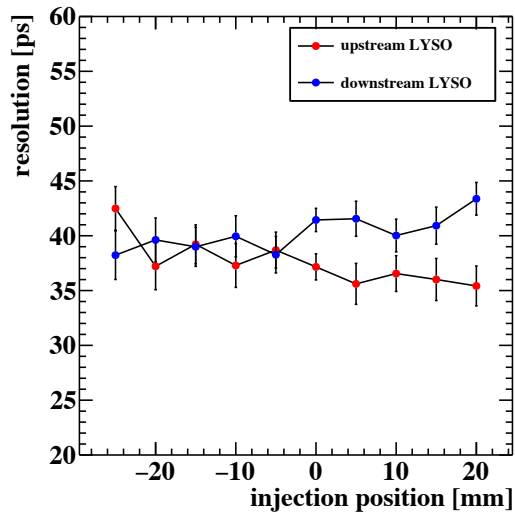

1.5x5x50F independent_ver2

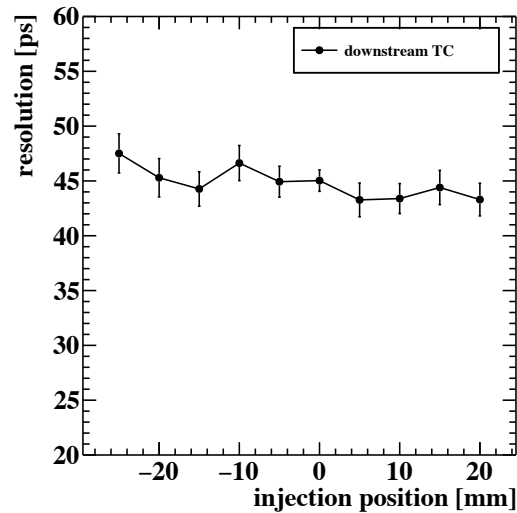

1.5x5x50F independent_ver2 downLYSO upTC

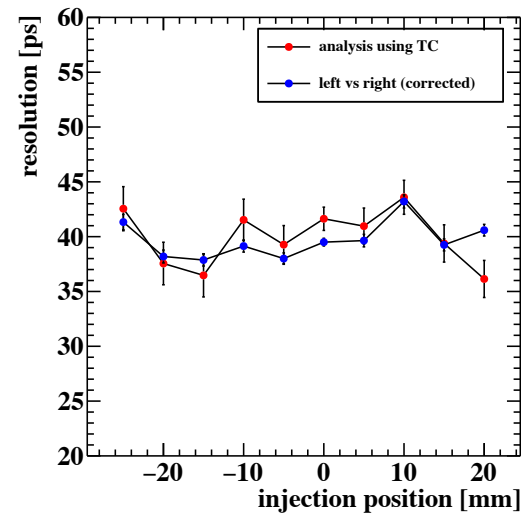

1.5x5x50F independent_ver2 downLYSO downTC

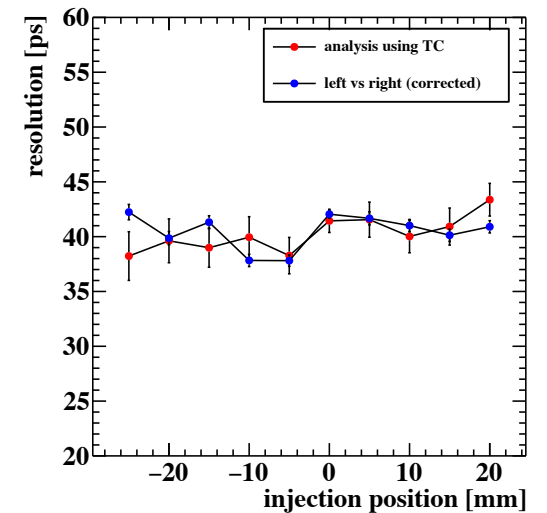

3 x 5 x 100 (independent) position scan

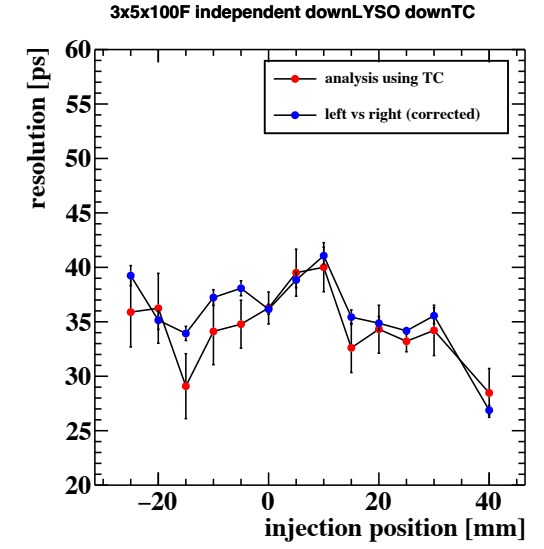
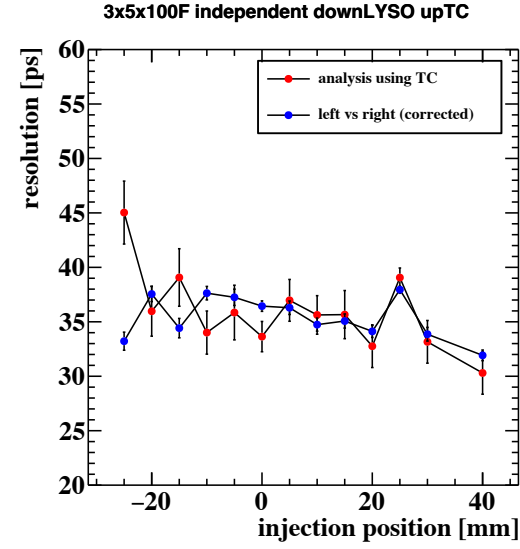
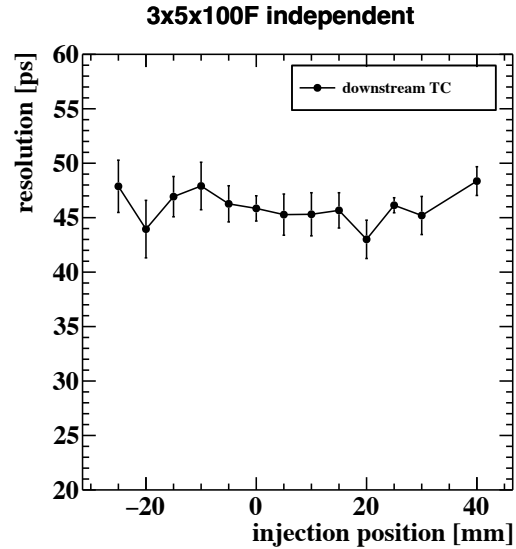
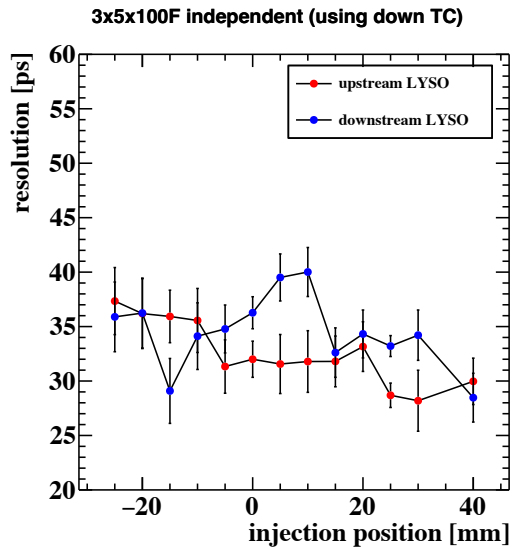
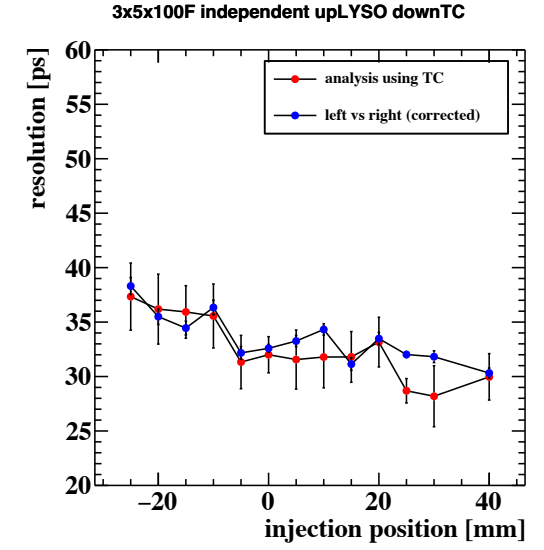
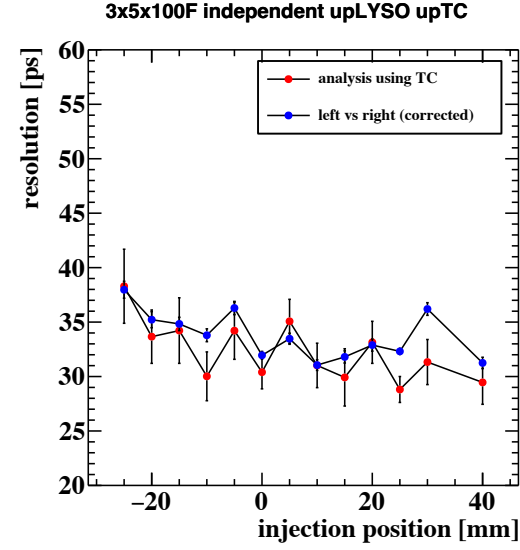
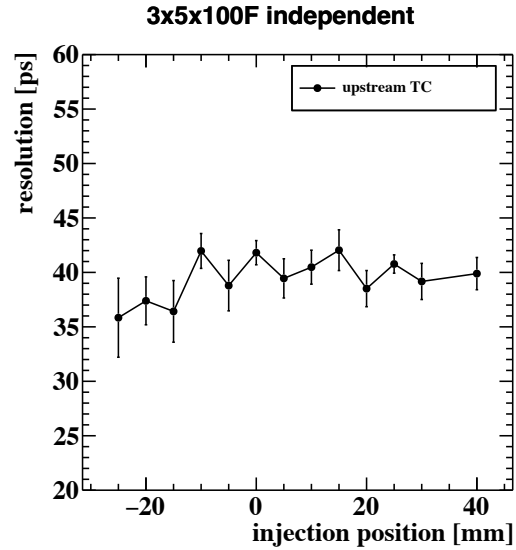
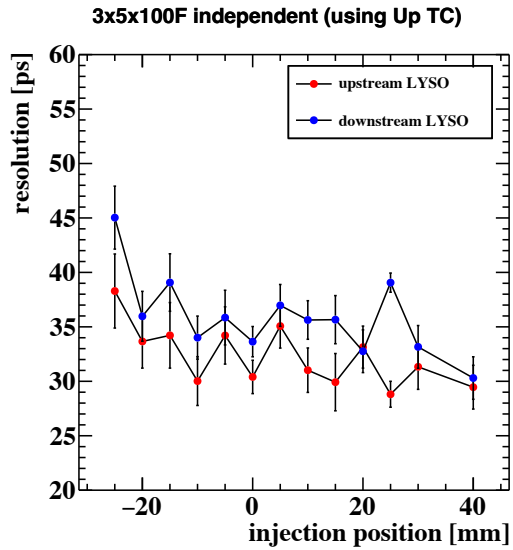

3 x 10 x 50 (independent) position scan

3x10x50F independent upLYSO upTC

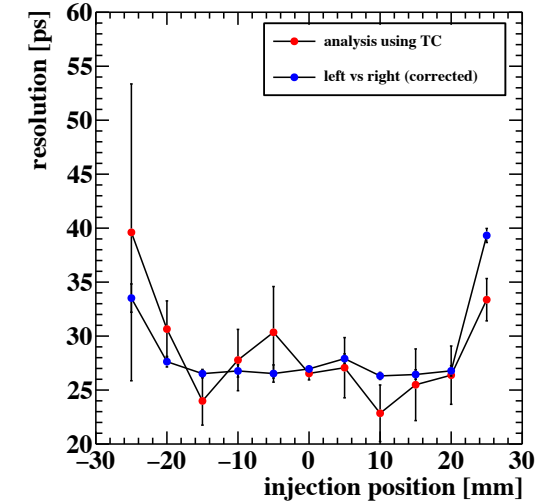

3x10x50F independent upLYSO downTC

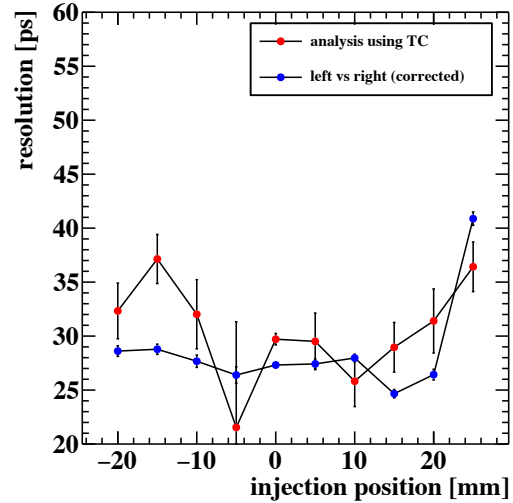

3x10x50F independent (using Up TC)

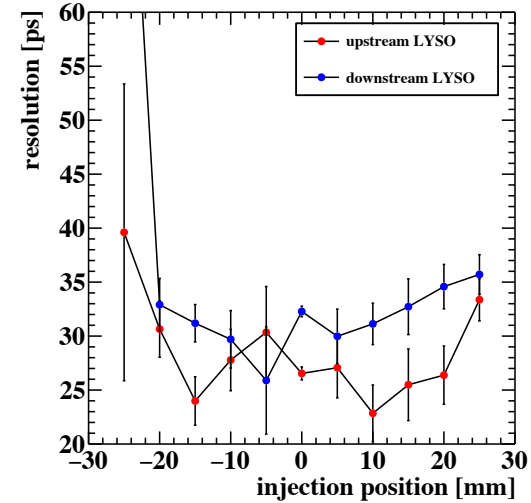

3x10x50F independent

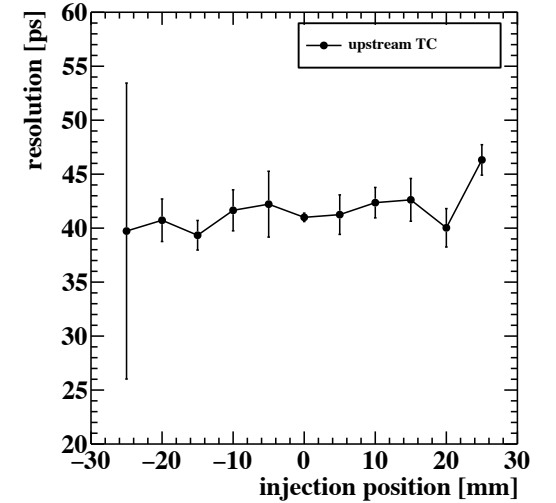

3x10x50F independent downLYSO upTC

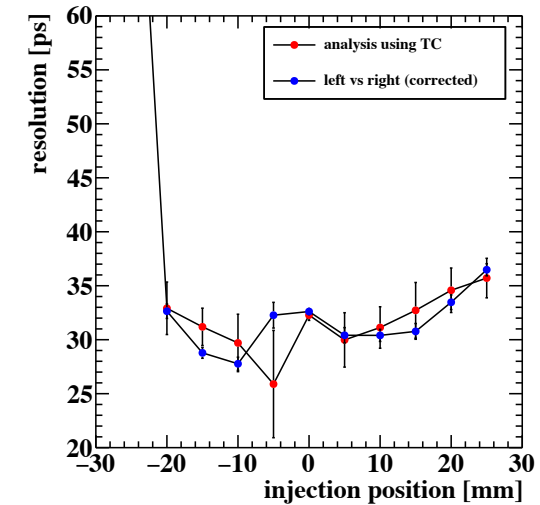

3x10x50F independent downLYSO downTC

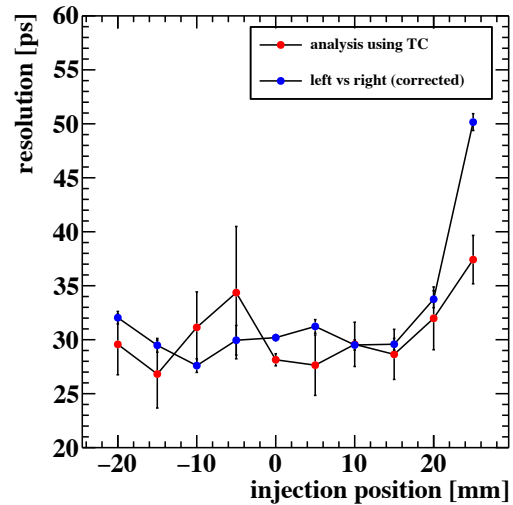

3x10x50F independent (using down TC)

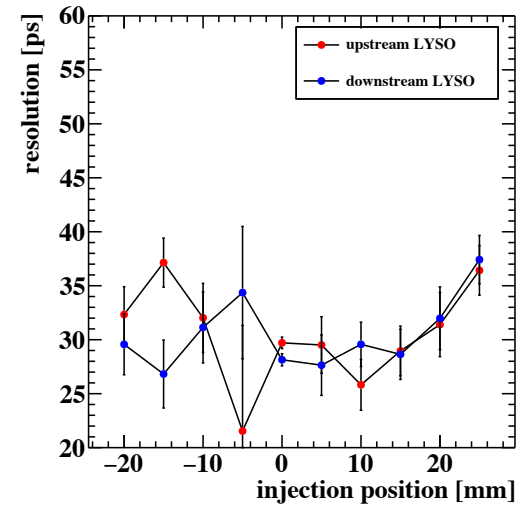

3x10x50F independent

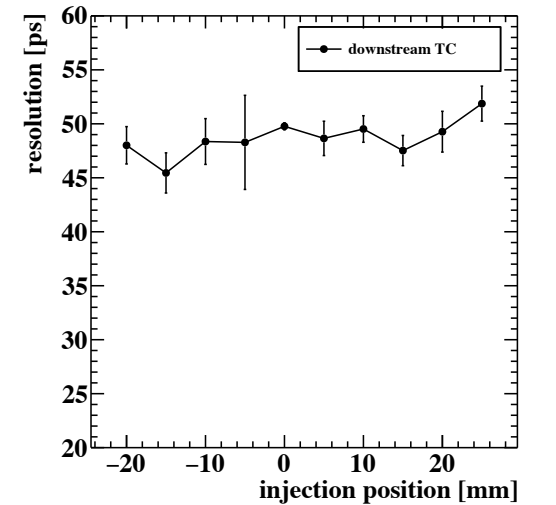

3 x 10 x 50 (series) position scan

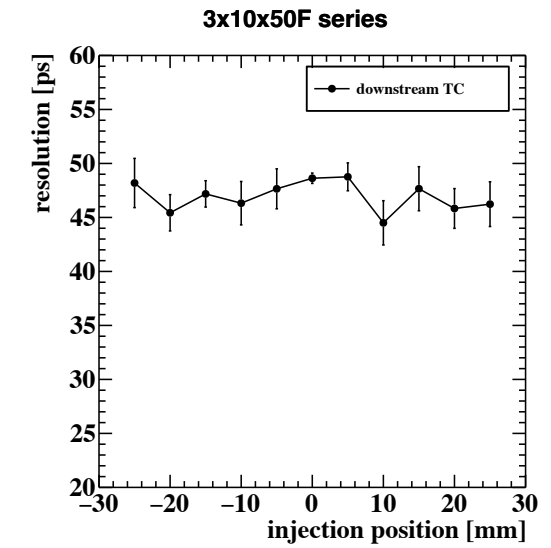
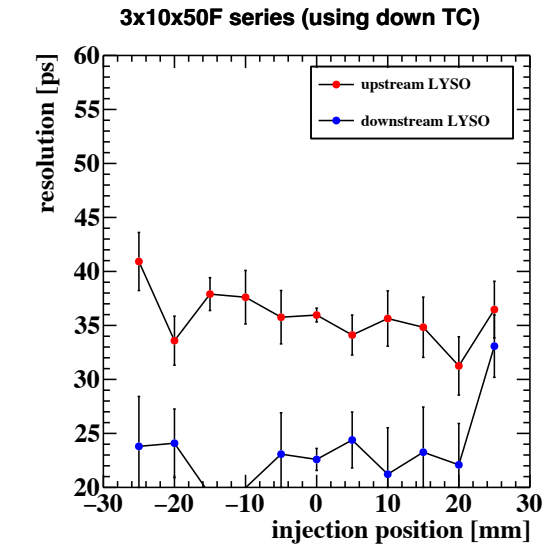
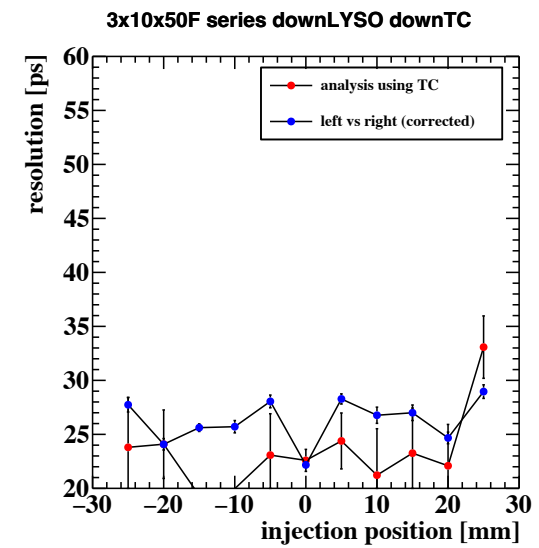
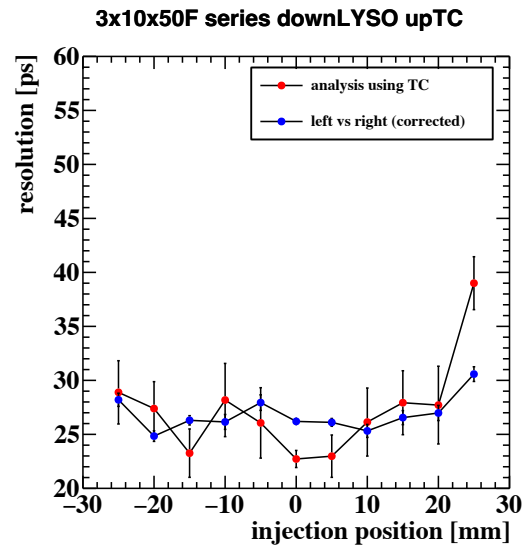
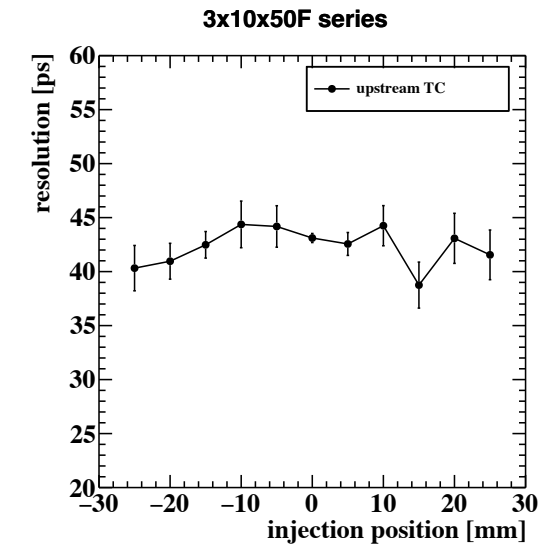
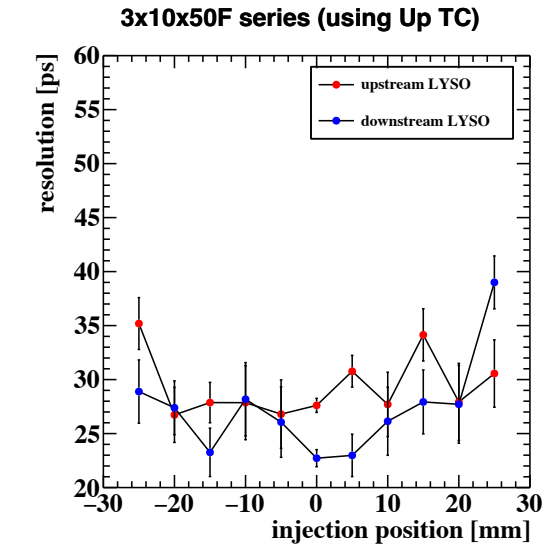
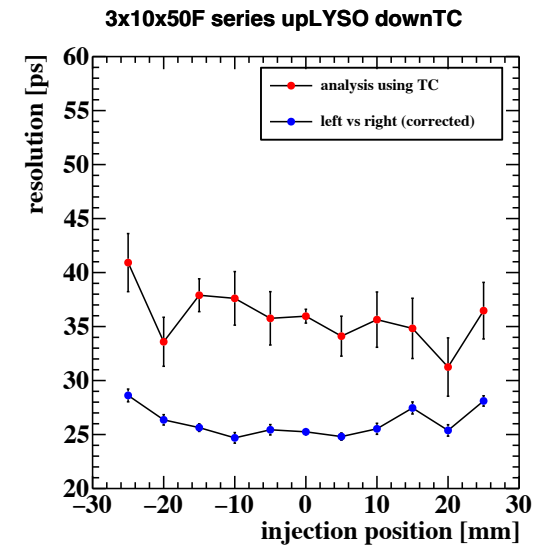
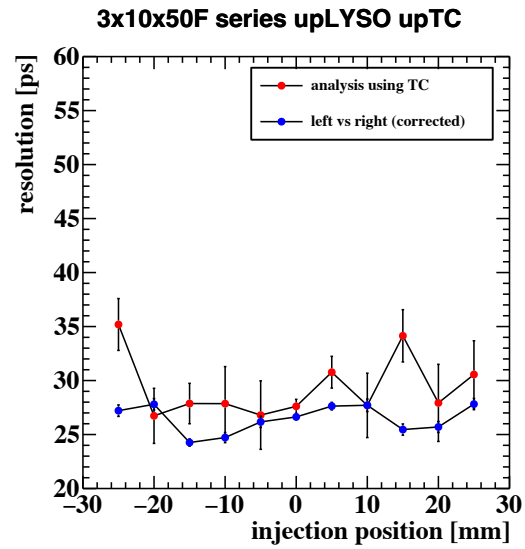

1.5 x 5 x 50 angle scan

1.5x5x50F independent_ver2 upLYSO upTC

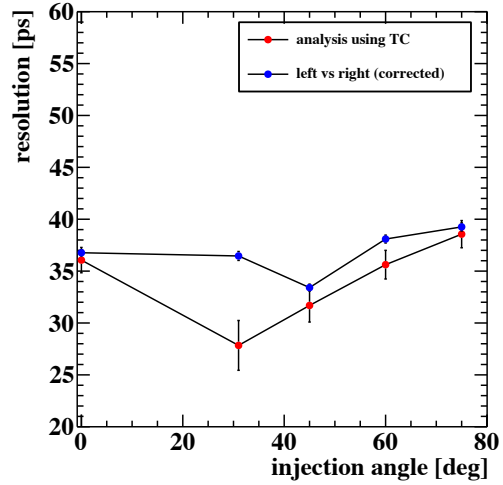

1.5x5x50F independent_ver2 upLYSO downTC

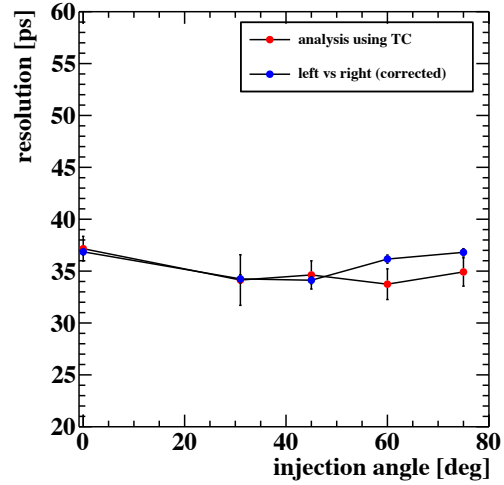

1.5x5x50F independent_ver2 (using Up TC)

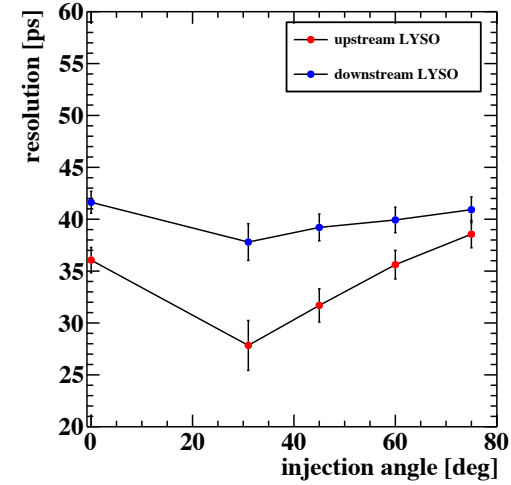

1.5x5x50F independent_ver2

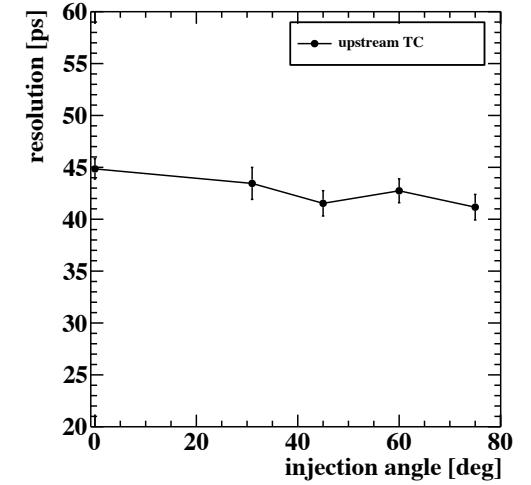

1.5x5x50F independent_ver2 downLYSO upTC

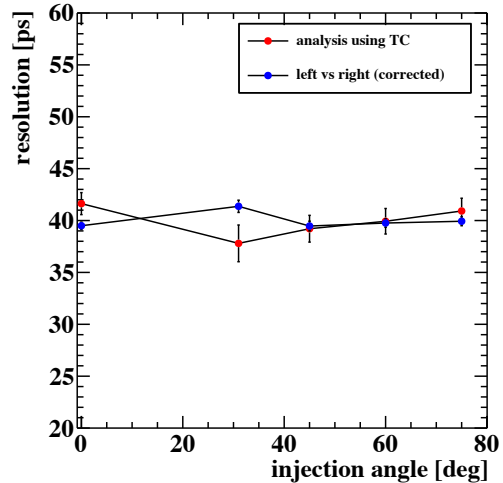

1.5x5x50F independent_ver2 downLYSO downTC

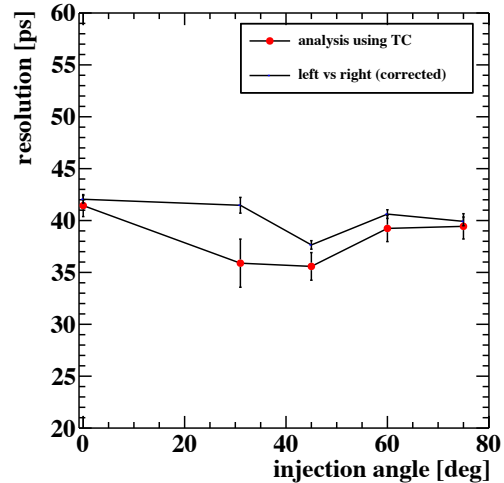

1.5x5x50F independent_ver2 (using down TC)

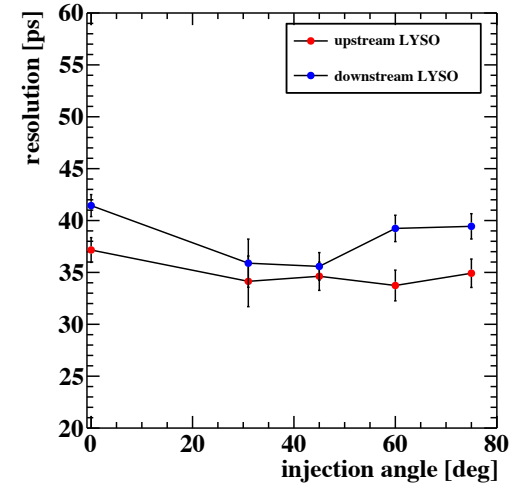

1.5x5x50F independent_ver2

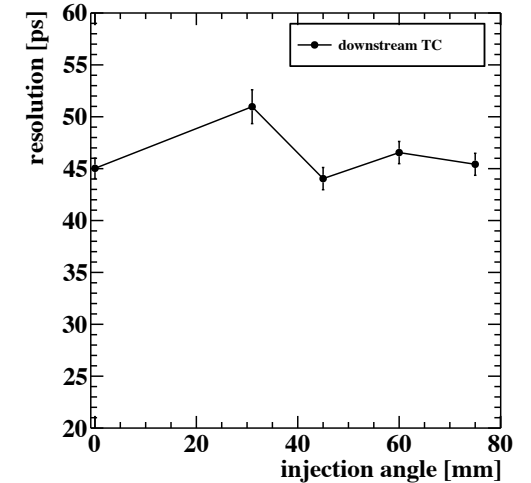

3 x 10 x 50 angle scan

3x10x50F independent (using Up TC)

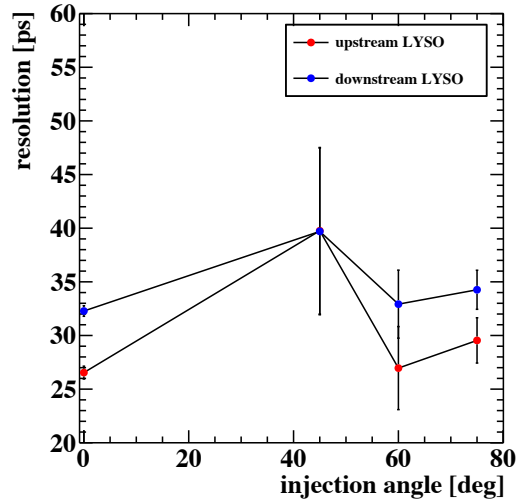

3x10x50F independent

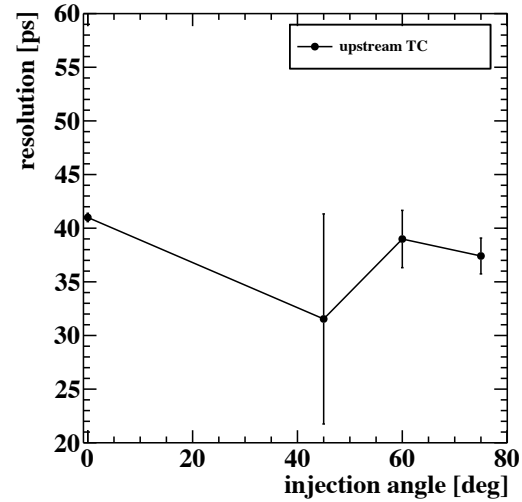

3x10x50F independent upLYSO upTC

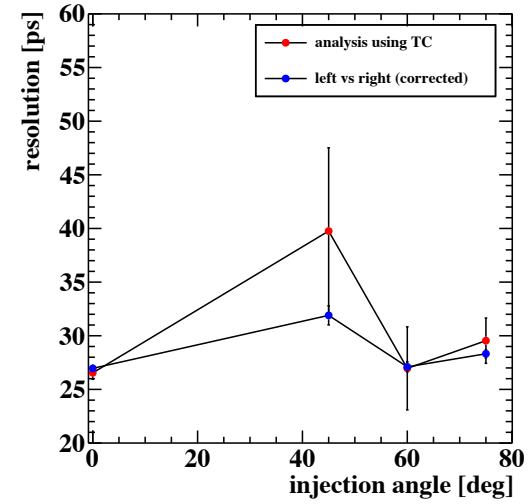

3x10x50F independent upLYSO downTC

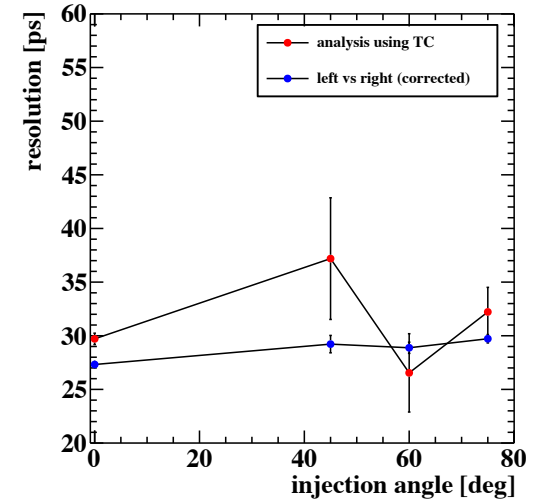

3x10x50F independent (using down TC)

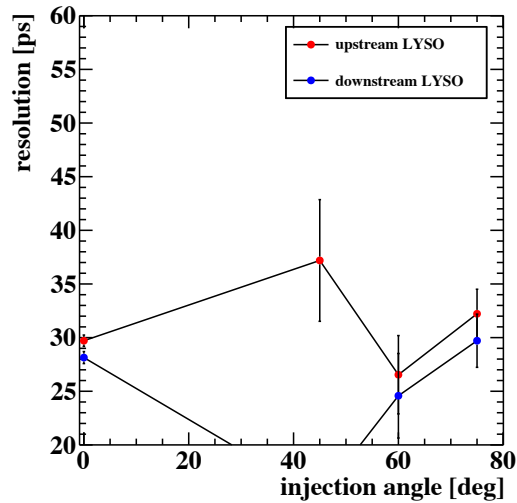

3x10x50F independent

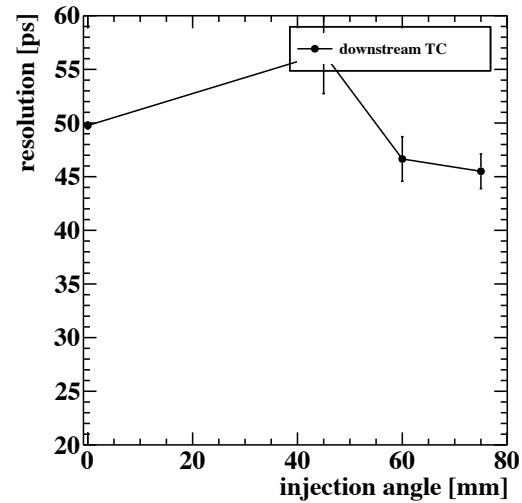

3x10x50F independent downLYSO upTC

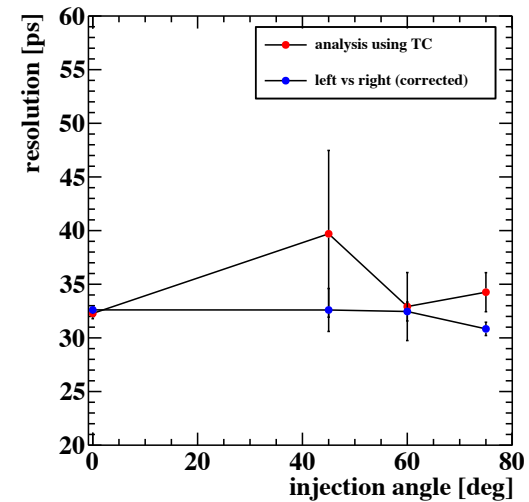

3x10x50F independent downLYSO downTC

